

Solid-Drive™

Fasteners for Structural Wood Applications

SIMPSON

Strong-Tie®

High-Performance Structural Wood Fasteners.



Fasteners engineered with engineers in mind.

Solid-Drive fasteners make the jobs of engineers and builders easier. Their high-performance design increases your allowable loads while speeding installation — lowering labor and materials costs. Our ETA documentation gives engineers higher safety and flexibility in their specification of wood structures and includes thorough documentation of CLT, LVL and rafter insulation fastening.

You can specify screws and nails easily with our Solid Wood software, and quickly get the products you need from our nationwide network of suppliers. Quality. Speed. Strength. Availability. Work smarter with Simpson Strong-Tie® fasteners.

To learn more, go to strongtie.eu



Our fasteners have been used in the Sara Cultural Centre in Sweden.

With its 20 floors that extends about 80 meters up from the ground, the building is currently one of the tallest CLT houses in the world.



Solid-Drive screws for CLT and mass timber applications.

You can find all formulas for making the calculations for CLT and mass timber fastening in our ETA. The quickest and easiest way for making CLT calculations, is to use our software Solid Wood, where you can get all the needed load values for your application, in just four simple steps.



Inclined installations.

For inclined and angled installations of our Solid-Drive screws, we recommend using our GSCREW installation guide which ensures that the screws are installed with the correct angle. See page 13.

Double threaded screws with clamping effect.

SWD is a double threaded structural screw designed to connect and pull together two wood members. See page 12.





Benefits of using our ETA-approved fasteners

The ETA-21/0670 describes the properties of our main line of fasteners for structural timber constructions, in depth. For you, the ETA works as documentation that the fasteners have been rigorously tested. This ensures that you can rely on our documentation as the basis for your calculations and specifications of the products.

There are a number of specific advantages when using ETA certified fasteners compared to using fasteners that are CE marked according to a harmonized European standard. This gives you more installation possibilities when using our fasteners. In the table below we have listed some of these advantages:

Comparison of CE certified screws acc. to EN14592 and Eurocode 5 vs. ETA-21/0670

Property	EN14592 and Eurocode 5 	ETA-21/0670 
CLT calculations	Not included	Included in ETA ¹
LVL calculations	Partially included in EC5	Included in ETA ²
Calculations for rafter insulation	Not included	Included in ETA ³
Withdrawal 0°	Not included	Tested and approved for structural installations in any directions vs the grain direction 0-90°. (SWD screws with 8 mm thread diameter approved between 15-90°.)
Pre-drilling	Mandatory from d = 8 mm	Not required
Bending angle / ductility	Limited by 45/d ^{0.7} degrees	Tested and approved for a 20° higher bending angle than the standard.
Space and edge distance	EC5 = (without examination)	Improved space and edge distance for SWD screws. The reduced values gives the opportunity to add more fasteners to the connection on a smaller area and get closer to the edges without pre-drilling.
Extended test program	10 test specimens per characteristic parameter	Extended number of test specimens per characteristic parameter
Displacement requirement Head Pull-through	No limitations	Test stopped at max. 15 mm displacement

¹⁾ Solid-Drive screws that are included in ETA-21/0670 can be used for CLT applications, you find all formulas for making the calculations in our ETA approval and also the space and edge distances. The quickest and easiest way for making CLT calculations is to use our software Solidwood where you in four simple steps can get load values based on your application.

²⁾ In the ETA-21/0670 you find support for LVL (softwood) calculations for all Solid-Drive Fasteners.

³⁾ Screws with diameters between 6 mm and 12 mm may also be used for the fixing of thermal insulation material on rafters and on vertical facades, you find the calculations in the ETA.

Advantages of using full- & double threaded structural timber screws:

Full threaded and double threaded structural timber screws provide extreme strength and are therefore highly suitable in mass timber applications, such as CLT, glulam, LVL etc.

While full threaded screws create a tight assembly, our double threaded SWD screw create a clamping effect between the two wood members.

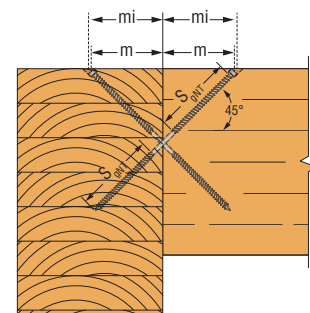
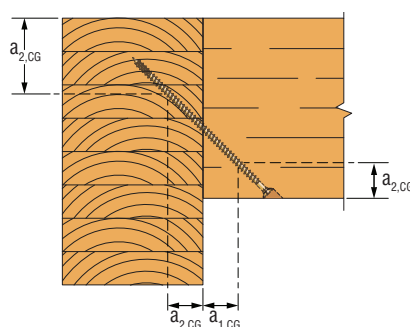
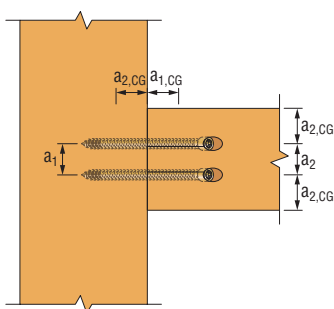

CLT and glulam applications

As the use of mass timber is growing in the construction industry all over the world, the need for high-quality structural fasteners is becoming increasingly evident. Engineers, contractors and mass timber manufacturers need solutions that can help them make their jobs easier, with better documentation, specification tools, and of course the right products, available at the right place, at the right time.

Our structural fasteners have been rigorously tested in a variety of mass timber applications. Our experts provide technical support and onsite guidance.

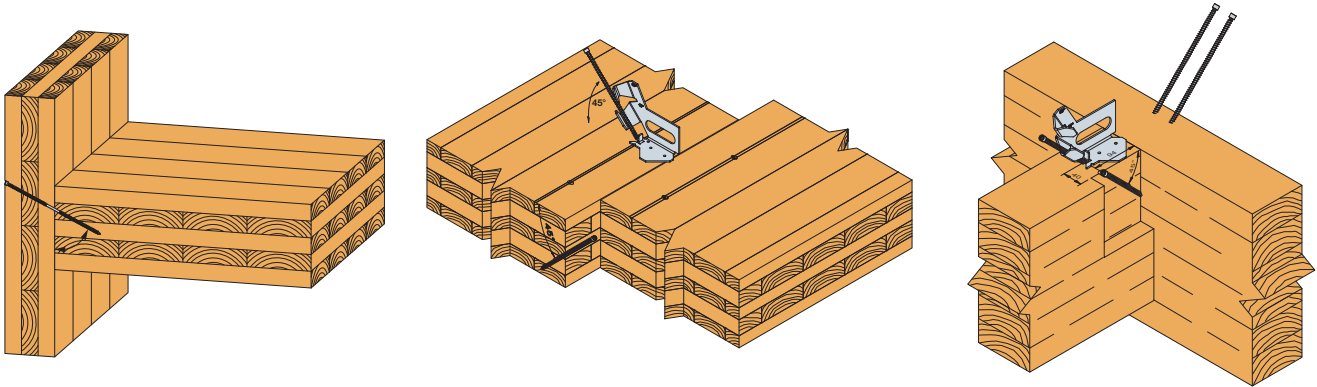

Rafter insulation applications

Long structural screws are ideal for the installation of thermal insulation material on rafters and on vertical facades. The different designs of the screws provide a variety of different solutions.

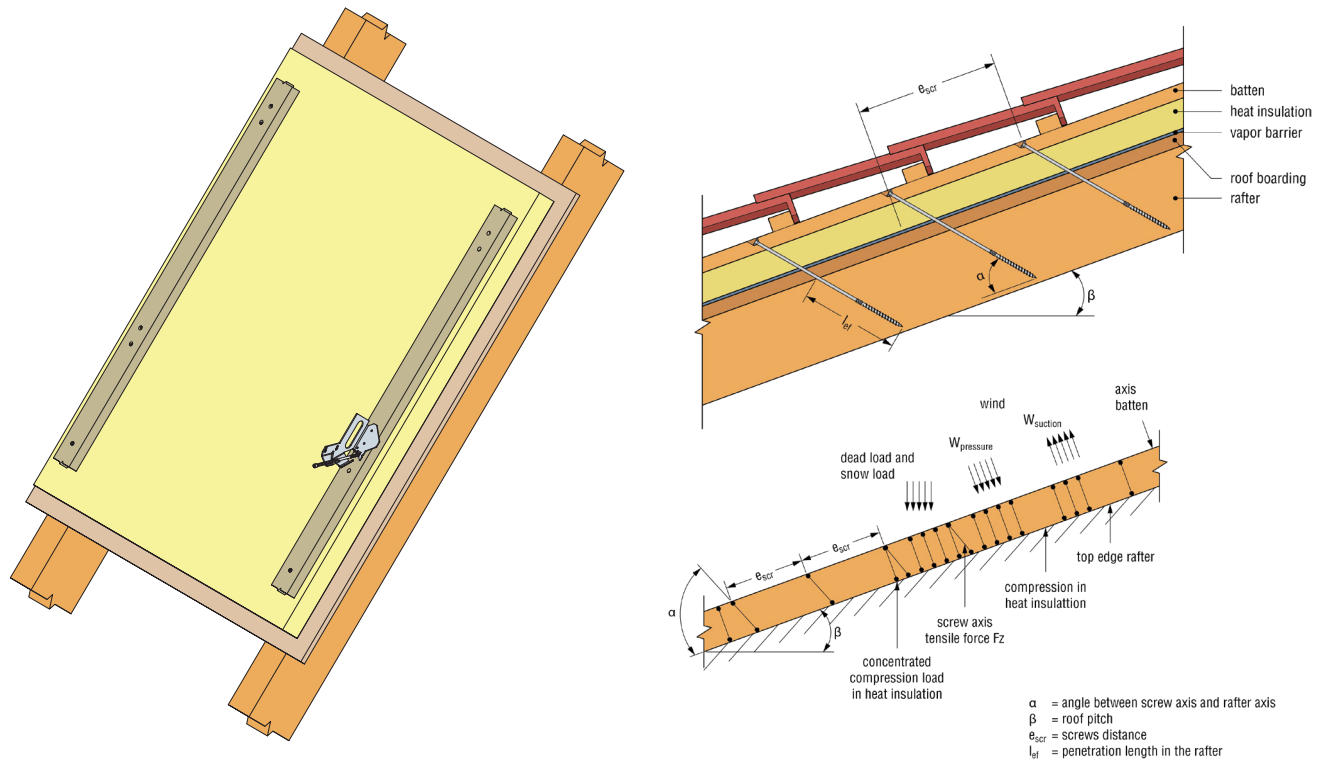

© SIMPSON STRONG-TIE® F-EU-SOLIDDRIVE-2022



Solid Wood Fastener Dimensioning Software

In just four simple steps, Solid Wood guides you through the calculation and selection of fastening solutions suitable for the specific wood structure at hand, all according to Eurocode 5 and our ETA.

Try Solid Wood today. Go to solidwood.strongtie.eu



Solid-Drive™ Fastener Types and Sizes



ETA-21/0670

The Solid-Drive range consists of 22 high-quality fasteners designed to meet the demands of structural wood constructions.

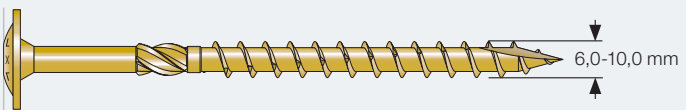
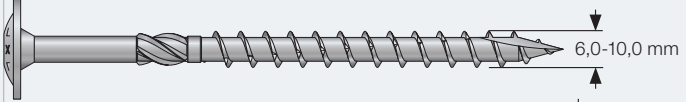
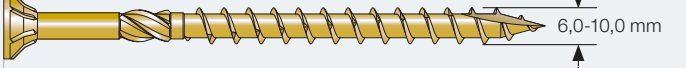
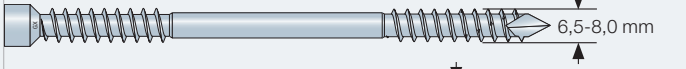
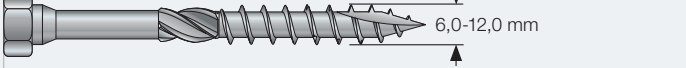
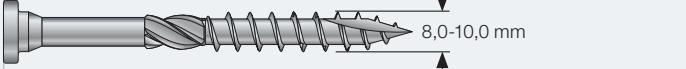
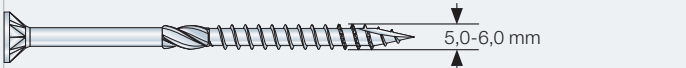
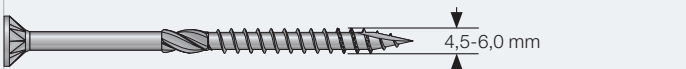

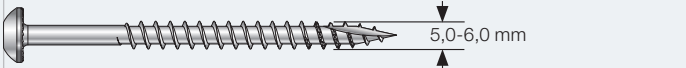
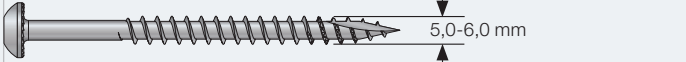

The first 11 screws shown in this window are approved according to ETA-21/0670, which gives them a number of benefits, that are presented in the table on page 4.

SWW 60-400 mm <i>See page 7</i>		6,0-10,0 mm
SWWZ 80-340 mm <i>See page 9</i>		6,0-10,0 mm
SWC 60-400 mm <i>See page 10</i>		6,0-10,0 mm
SWD 65-330 mm <i>See page 12</i>		6,5-8,0 mm
SSH 40-300 mm <i>See page 14</i>		6,0-12,0 mm
SSF 40-80 mm <i>See page 16</i>		8,0-10,0 mm
TTSFS 60-140 mm <i>See page 18</i>		5,0-6,0 mm
TTZNFS 50-180 mm <i>See page 19</i>		4,5-6,0 mm
TTUFS 50-180 mm <i>See page 20</i>		4,5-6,0 mm
TTUFP 30-100 mm <i>See page 21</i>		5,0-6,0 mm
TTZNFP 40-100 mm <i>See page 21</i>		5,0-6,0 mm

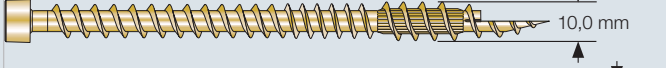
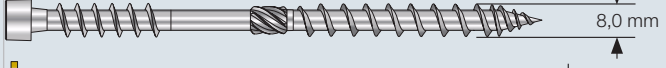
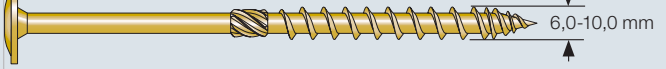

ETA-13/0796

The ESCR range consists of a number of full threaded screws as well as double threaded and partially threaded timber screws, that are approved according to ETA-13/0796.

ESCRFTC 120-600 mm <i>See page 22</i>		8,0-12,0 mm
ESCRFTZ 120-400 mm <i>See page 24</i>		8,0 mm
ESCRFT 450-1000 mm <i>See page 24</i>		10,0 mm
ESCRT2R 240-450 mm <i>See page 26</i>		8,0 mm
ESCR 60-400 mm <i>See page 28</i>		6,0-10,0 mm
ESCRC 50-400 mm <i>See page 30</i>		5,0-10,0 mm



ETA-04/0013

Our CNA connector nails and CSA connector screws are ETA-approved according to ETA-04/0013.

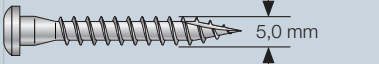

CNA 35-100 mm <i>See page 32</i>		4,0-6,0 mm
CSA 25-80 mm <i>See page 34</i>		5,0 mm



EN14592

Furthermore, the Solid-Drive range includes three wood-framing screws which are CE-marked according to EN14592.

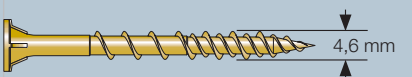
With this range we give you precision engineered to meet any demand.

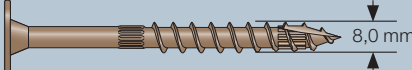
WSV 44-76 mm <i>See page 36</i>		4,6 mm
SDW 68-152 mm <i>See page 37</i>		7,9 mm
SDWS 75-252 mm <i>See page 37</i>		8,0 mm

Solid-Drive™ SWW/SWWZ Structural Washer Head WOOD Screw

The Solid-Drive® SWW and SWWZ partially threaded washer head wood screw is a structural fastener available in a variety of dimensions and is designed for cross-laminated timber (CLT) and glulam construction, as well as general interior wood applications.

These partially-threaded, 6.0, 8.0 and 10.0 diameter [mm] structural fasteners are designed to pull structural members together with superb holding power and excellent load capacity. The large washer head provides extreme pull-through resistance while allowing the wood members to close up firmly. Predrilling is not typically required. For interior and dry applications only.

Application

- CLT Wall-to-Wall, Floor-to-Wall, Panel-to-Beam
- Panel-to-Wall, Surface Spline, Lap Joint and Ledger Connections; General Timber Framing



SWW screws installed into a T-connection between two walls.



SWW screw installed into a CLT floor-to-wall connection.



Features



Deep 6-lobe recess provides improved control and greater bit life

© SIMPSON STRONG-TIE® F-EU-SOLIDDRIVE-2022



ETA-21/0670

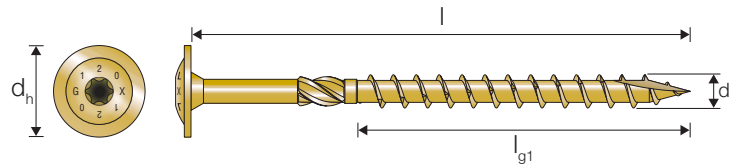

SWW Yellow Zinc Plated

Model No.	Item code	Dimensions [mm]				Bit	
		d	l	d _h	l _g		
SWW6.0X60	75382	6.0	60	14	42	T-30	50
SWW6.0X80	75383	6.0	80	14	50	T-30	50
SWW6.0X100	75384	6.0	100	14	70	T-30	50
SWW6.0X120	75385	6.0	120	14	70	T-30	50
SWW6.0X140	75386	6.0	140	14	70	T-30	50
SWW6.0X160	75387	6.0	160	14	70	T-30	50
SWW6.0X180	75388	6.0	180	14	70	T-30	50
SWW6.0X200	75389	6.0	200	14	70	T-30	50
SWW6.0X220	75390	6.0	220	14	70	T-30	50
SWW6.0X240	75391	6.0	240	14	70	T-30	50
SWW6.0X260	75392	6.0	260	14	70	T-30	50
SWW6.0X280	75393	6.0	280	14	70	T-30	50
SWW6.0X300	75394	6.0	300	14	70	T-30	50
SWW8.0X80	75395	8.0	80	22.2	50	T-40	50
SWW8.0X100	75396	8.0	100	22.2	50	T-40	50
SWW8.0X120	75397	8.0	120	22.2	80	T-40	50
SWW8.0X140	75398	8.0	140	22.2	80	T-40	50
SWW8.0X160	75399	8.0	160	22.2	80	T-40	50
SWW8.0X180	75400	8.0	180	22.2	80	T-40	50
SWW8.0X200	75401	8.0	200	22.2	80	T-40	50
SWW8.0X220	75402	8.0	220	22.2	80	T-40	50
SWW8.0X240	75403	8.0	240	22.2	80	T-40	50
SWW8.0X260	75404	8.0	260	22.2	80	T-40	50
SWW8.0X280	75405	8.0	280	22.2	80	T-40	50
SWW8.0X300	75406	8.0	300	22.2	80	T-40	50
SWW8.0X320	75407	8.0	320	22.2	80	T-40	50
SWW8.0X340	75408	8.0	340	22.2	80	T-40	50
SWW8.0X360	75409	8.0	360	22.2	80	T-40	50
SWW8.0X380	75410	8.0	380	22.2	80	T-40	50
SWW8.0X400	75411	8.0	400	22.2	80	T-40	50
SWW10.0X100	76912	10.0	100	25.9	50	T-40	25
SWW10.0X120	76913	10.0	120	25.9	50	T-40	25
SWW10.0X140	76914	10.0	140	25.9	80	T-40	25
SWW10.0X160	75412	10.0	160	25.9	80	T-40	25
SWW10.0X180	75413	10.0	180	25.9	80	T-40	25
SWW10.0X200	75414	10.0	200	25.9	80	T-40	25
SWW10.0X220	75415	10.0	220	25.9	80	T-40	25
SWW10.0X240	75416	10.0	240	25.9	80	T-40	25
SWW10.0X260	75417	10.0	260	25.9	80	T-40	25
SWW10.0X280	75418	10.0	280	25.9	80	T-40	25
SWW10.0X300	75419	10.0	300	25.9	80	T-40	25
SWW10.0X320	75420	10.0	320	25.9	80	T-40	25
SWW10.0X340	75421	10.0	340	25.9	80	T-40	25
SWW10.0X360	75422	10.0	360	25.9	80	T-40	25
SWW10.0X380	75423	10.0	380	25.9	80	T-40	25
SWW10.0X400	75424	10.0	400	25.9	80	T-40	25

For additional technical data, such as load-bearing capacities, installation data and more, visit our website www.strongtie.eu.



ETA-21/0670

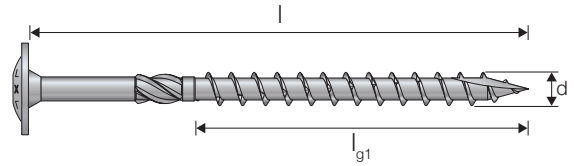
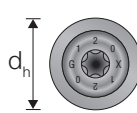

SWWZ Impreg®+

Model No.	Item code	Dimensions [mm]				Bit	
		d	l	d _h	l _g		
SWWZ6.0X80	76352	6.0	80	14	50	T-30	50
SWWZ6.0X90	76452	6.0	90	14		T-30	50
SWWZ6.0X100	76453	6.0	100	14	70	T-30	50
SWWZ6.0X120	76454	6.0	120	14	70	T-30	50
SWWZ8.0X80	76455	8.0	80	22.2	50	T-40	50
SWWZ8.0X90	76457	8.0	90	22.2		T-40	50
SWWZ8.0X100	76601	8.0	100	22.2	50	T-40	50
SWWZ8.0X120	76603	8.0	120	22.2	80	T-40	50
SWWZ8.0X140	76604	8.0	140	22.2	80	T-40	50
SWWZ8.0X180	76605	8.0	180	22.2	80	T-40	50
SWWZ8.0X200	76606	8.0	200	22.2	80	T-40	50
SWWZ8.0X240	76607	8.0	240	22.2	80	T-40	50
SWWZ8.0X300	76608	8.0	300	22.2	80	T-40	50
SWWZ8.0X340	76609	8.0	340	22.2	80	T-40	50
SWWZ10.0X160	76610	10.0	160	25.9	80	T-40	25
SWWZ10.0X180	76611	10.0	180	25.9	80	T-40	25
SWWZ10.0X200	76612	10.0	200	25.9	80	T-40	25
SWWZ10.0X240	76613	10.0	240	25.9	80	T-40	25

For additional technical data, such as load-bearing capacities, installation data and more, visit our website www.strongtie.eu.

Impreg®+

Impreg+ is an electrolytic, inorganic, surface treatment consisting of zinc and nickel. Due to the strong alloy combination the coating is very robust and suitable for corrosive environments.



- Compliant with REACH, RoHS- and ELV-directive
- Chromium (VI) free
- No galvanic corrosion in aluminium connections
- Due to the strong adhesion between the steel and the coating, Impreg+ will maintain the corrosion resistance even after installation
- Withstands temperatures up to 300° (C)
- C4 approved for 15 years according to EN ISO 11997-1:2017, cycle B

Comparison test EN ISO 11997-1:2017, Cycle B, 1240 hours, low (electro galvanised), medium (Impreg+), severe (stainless steel A4).

Solid-Drive™ SWC Structural Countersunk WOOD Screw

The Solid-Drive® SWC partially threaded wood screw is a structural fastener available in a variety of dimensions and is designed for cross-laminated timber (CLT) and glulam construction, as well as general interior wood applications.

These partially-threaded, 6.0, 8.0 and 10.0 diameter [mm] structural fasteners are designed to pull structural members together with superb holding power and excellent load capacity. The countersunk head and underhead nibs provide for clean countersinking, flush with the surface. Predrilling is not typically required. For interior and dry applications only.

Application

- CLT Wall-to-Wall, Floor-to-Floor, Panel-to-Beam
- Panel-to-Wall, Surface Spline, Lap Joint and Ledger Connections; General Timber Framing



ETA-21/0670

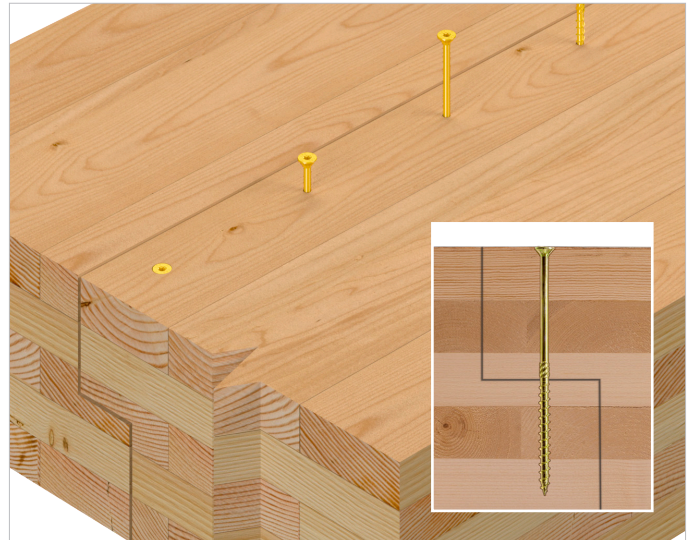

SWC screws installed into a CLT lap joint.



SWC screw installed into a CLT spline.

Features

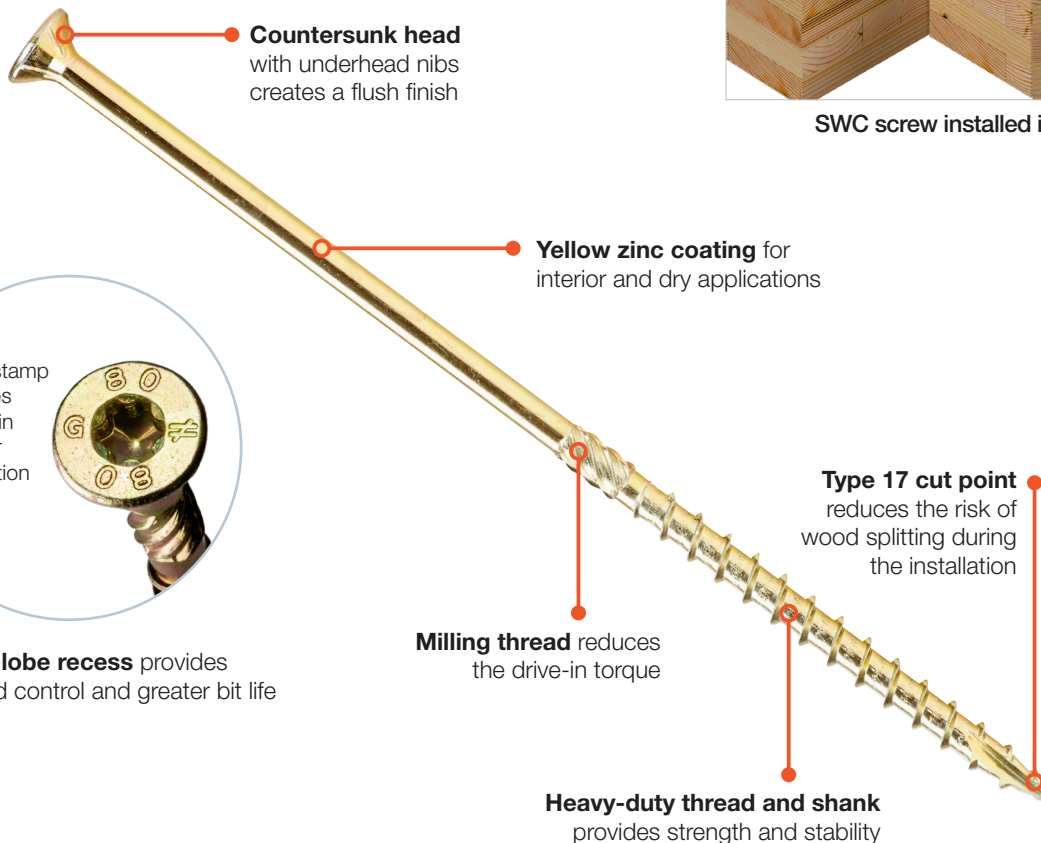

© SIMPSON STRONG-TIE® F-EU-SOLIDDRIVE-2022



ETA-21/0670

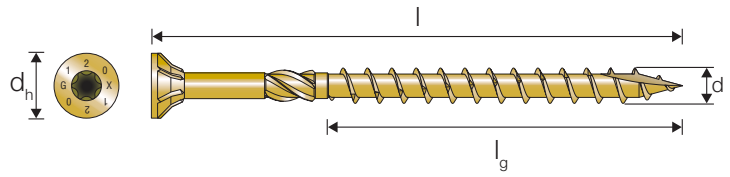

SWC Yellow Zinc Plated

Model No.	Item code	Dimensions [mm]				Bit	
		d	l	d _h	l _g		
SWC6.0X200	75346	6.0	200	11.8	70	T-30	100
SWC6.0X220	75347	6.0	220	11.8	70	T-30	100
SWC6.0X240	75348	6.0	240	11.8	70	T-30	100
SWC6.0X260	75349	6.0	260	11.8	70	T-30	100
SWC6.0X280	75350	6.0	280	11.8	70	T-30	100
SWC6.0X300	75351	6.0	300	11.8	70	T-30	100
SWC8.0X80	75352	8.0	80	14.6	50	T-40	50
SWC8.0X100	75353	8.0	100	14.6	50	T-40	50
SWC8.0X120	75354	8.0	120	14.6	80	T-40	50
SWC8.0X140	75355	8.0	140	14.6	80	T-40	50
SWC8.0X160	75356	8.0	160	14.6	80	T-40	50
SWC8.0X180	75357	8.0	180	14.6	80	T-40	50
SWC8.0X200	75358	8.0	200	14.6	80	T-40	50
SWC8.0X220	75359	8.0	220	14.6	80	T-40	50
SWC8.0X240	75360	8.0	240	14.6	80	T-40	50
SWC8.0X260	75361	8.0	260	14.6	80	T-40	50
SWC8.0X280	75362	8.0	280	14.6	80	T-40	50
SWC8.0X300	75363	8.0	300	14.6	80	T-40	50
SWC8.0X320	75364	8.0	320	14.6	80	T-40	50
SWC8.0X340	75365	8.0	340	14.6	80	T-40	50
SWC8.0X360	75366	8.0	360	14.6	80	T-40	50
SWC8.0X380	75367	8.0	380	14.6	80	T-40	50
SWC8.0X400	75368	8.0	400	14.6	80	T-40	50
SWC10.0X100	76916	10.0	100	17.8	50	T-40	25
SWC10.0X120	76917	10.0	120	17.8	50	T-40	25
SWC10.0X140	76918	10.0	140	17.8	80	T-40	25
SWC10.0X160	75369	10.0	160	17.8	80	T-40	25
SWC10.0X180	75370	10.0	180	17.8	80	T-40	25
SWC10.0X200	75371	10.0	200	17.8	80	T-40	25
SWC10.0X220	75372	10.0	220	17.8	80	T-40	25
SWC10.0X240	75373	10.0	240	17.8	80	T-40	25
SWC10.0X260	75374	10.0	260	17.8	80	T-40	25
SWC10.0X280	75375	10.0	280	17.8	80	T-40	25
SWC10.0X300	75376	10.0	300	17.8	80	T-40	25
SWC10.0X320	75377	10.0	320	17.8	80	T-40	25
SWC10.0X340	75378	10.0	340	17.8	80	T-40	25
SWC10.0X360	75379	10.0	360	17.8	80	T-40	25
SWC10.0X380	75380	10.0	380	17.8	80	T-40	25
SWC10.0X400	75381	10.0	400	17.8	80	T-40	25

For additional technical data, such as load-bearing capacities, installation data and more, visit our website www.strongtie.eu.

Solid-Drive™ SWD Structural Double Threaded WOOD Screw

The Solid-Drive® SWD is a double threaded structural screw designed to connect and pull together two wood members.

The small cylinder head reduces the insertion torque and makes it possible to countersink the screws. The Protec+ coating is a wear resistant coating that can endure the friction of the installation and the exposure of high loads from the structural applications.

SWD screws are suitable for inclined and angled installations. Use the GSCREW screw guide to ensure that screws are installed with the correct angle into the timber.

Application

- CLT Wall-to-Wall, Floor-to-Floor, Panel-to-Beam
- Panel-to-Wall, Surface Spline, Lap Joint and Ledger Connections; General Timber Framing



SWD screws installed into a CLT wall-to-floor.



ETA-21/0670

Features

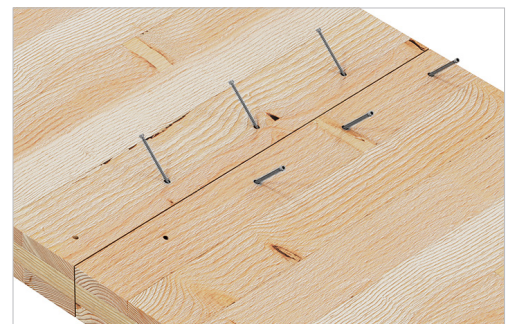
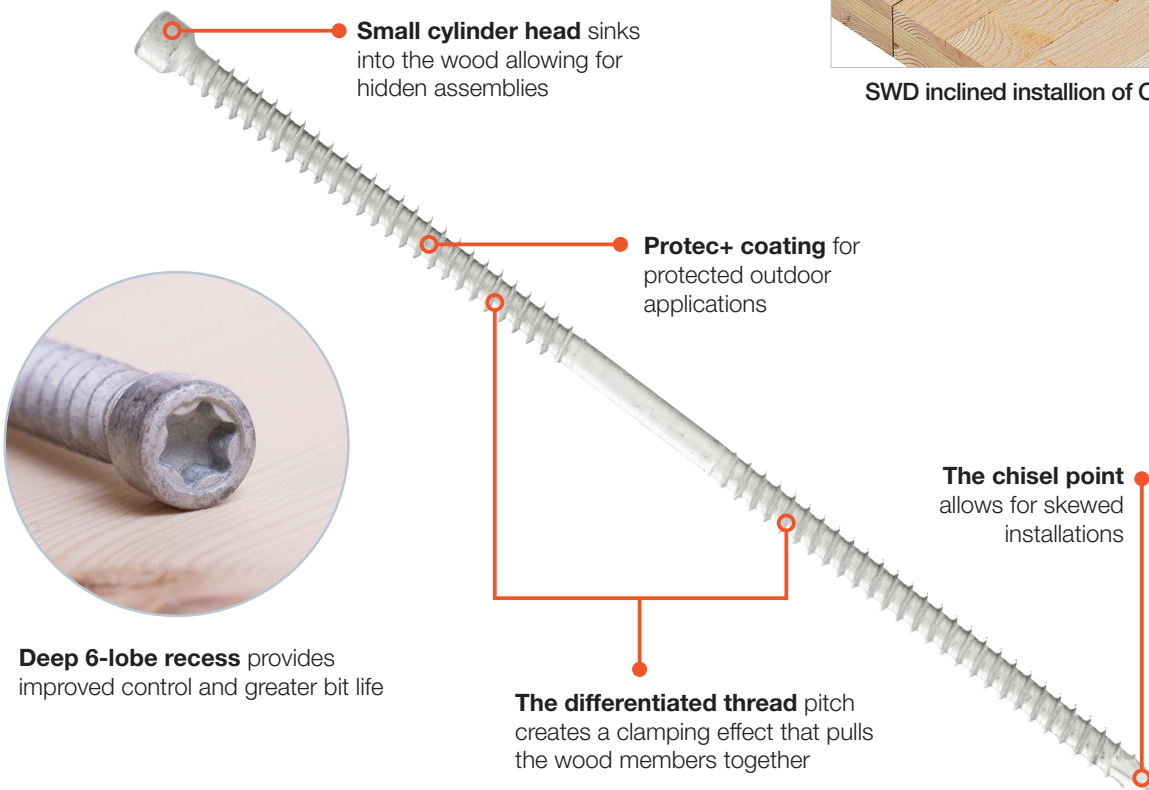

SWD inclined installation of CLT floor-to-floor.



ETA-21/0670

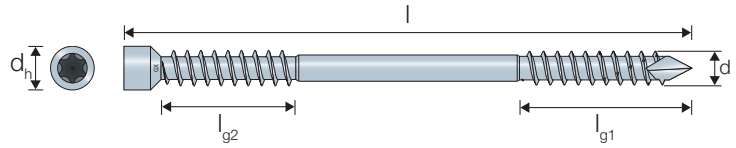

SWD Protec®+

Model No.	Item code	Dimensions [mm]					Bit	Box
		d	l	d _h	l _{g1}	l _{g2}		
SWD6.5X65	75425	6.5	65	8	28	21.5	T-30	50
SWD6.5X90	75426	6.5	90	8	40	33.5	T-30	50
SWD6.5X130	75427	6.5	130	8	40	33.5	T-30	50
SWD6.5X160	75428	6.5	160	8	65	58.5	T-30	50
SWD6.5X190	75429	6.5	190	8	80	73.5	T-30	50
SWD6.5X220	75430	6.5	220	10	95	88.5	T-30	50
SWD8.0X90	75431	8.0	90	10	40	31.5	T-40	50
SWD8.0X130	75432	8.0	130	10	40	31.5	T-40	50
SWD8.0X160	75433	8.0	160	10	65	56.5	T-40	50
SWD8.0X190	75434	8.0	190	10	80	71.5	T-40	50
SWD8.0X220	75435	8.0	220	10	95	86.5	T-40	50
SWD8.0X245	75436	8.0	245	10	107.5	99	T-40	50
SWD8.0X275	75437	8.0	275	10	107.5	99	T-40	50
SWD8.0X300	75438	8.0	300	10	135	126.5	T-40	50
SWD8.0X330	75439	8.0	330	10	135	126.5	T-40	50

For additional technical data, such as load-bearing capacities, installation data and more, visit our website www.strongtie.eu.

Structural screw guide for 45° and 60° inclined installations

The GSCREW4560 screw guide assists with the installation of any structural screws with a diameter between 8 and 12 mm with a skew angle of 45° or 60°.

The screw guide is suitable for the installation of full threaded screws or double threaded screws in structural timber, LVL, glulam or CLT applications or for fastening roof insulation, where 45° or 60° angled installations are common. However, it can also be used for any type of application as long as the screw is longer than 100 mm for a 45° configuration and longer than 140 mm for a 60° configuration.

This screw guide allows for easy installation of the screws at the required angle. [See more on pages 38-39.](#)

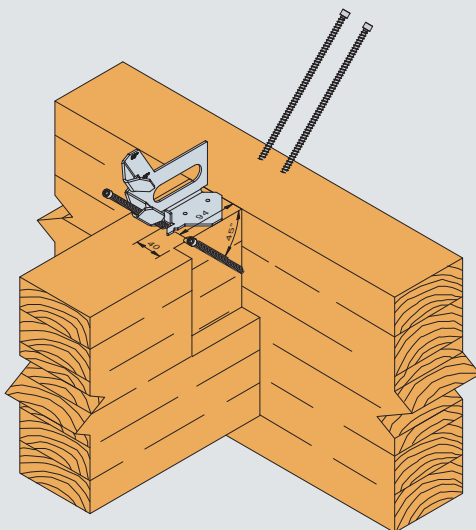

Solid-Drive™ SSH Hexagon Head CONNECTOR Screw

The Solid-Drive® SSH hex-head screw is a structural fastener designed for cross-laminated timber (CLT), glulam construction and general metal-to-wood applications.

These partially-threaded, sturdy 6.0, 8.0, 10.0 and 12.0 diameter (mm) structural fasteners are designed to provide excellent connection strength, especially when connecting steel plate or angle connectors to wood. The unique head combining Hex and torx allows for the convenience of driving with either a hex-driver bit or 6-lobe driver bit. The SSH screw has an exterior grade Impreg®+ coating, a robust knurled shank and type-17 point for fast starts and low-torque driving. The SSH screws are designed for indoor and outdoor applications.

Application

- Metal-to-Wood Connections

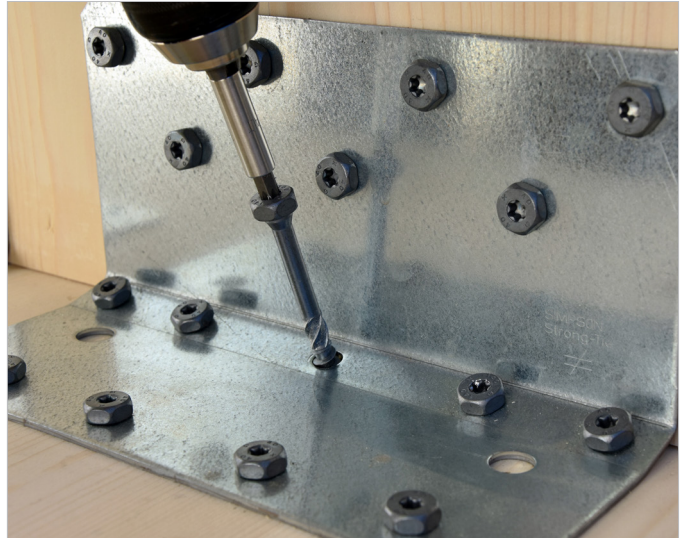

SSH screws fastening of AB255SSH angle bracket.



ETA-21/0670

Features

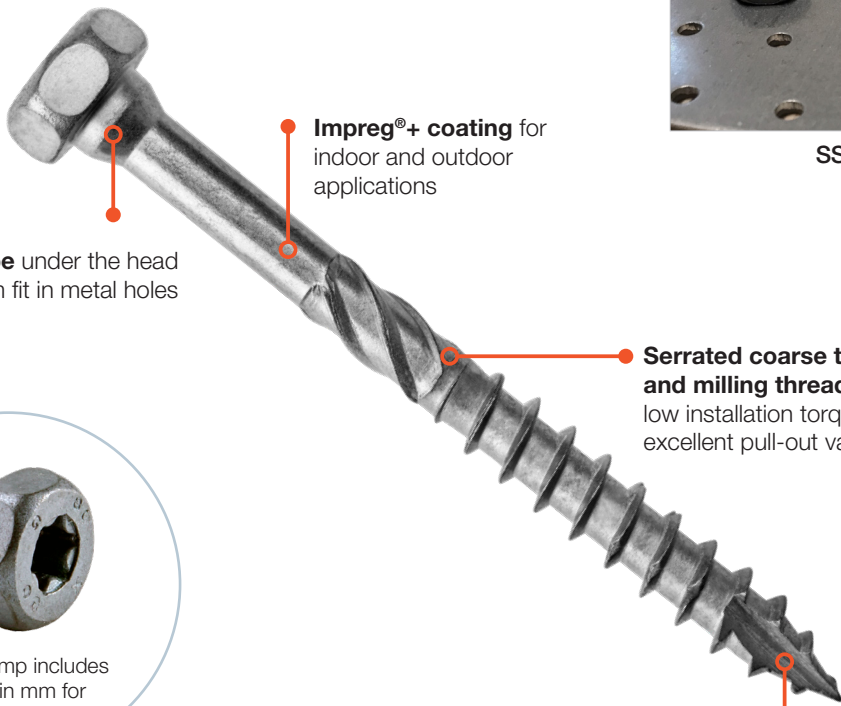

Conical shape under the head for maximum fit in metal holes

Impreg®+ coating for indoor and outdoor applications

Serrated coarse thread and milling thread for low installation torque and excellent pull-out values

Type 17 cut point reduces the risk of wood splitting during the installation



Hex-head with 6-lobe recess allows for the convenience of driving with either a hex-driver bit or 6-lobe driver bit

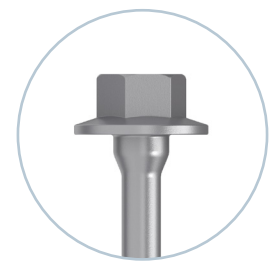

6.0 mm SSH screws have a slightly different head design



SSH screws screwed fastening of ABR255 angle bracket.

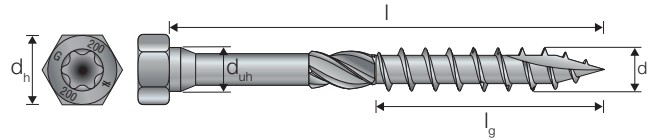

ETA-21/0670

SSH Impreg®+

Model No.	Item code	Dimensions [mm]				Thread*	Bit	
		d / d _{uh}	l	d _h	l _g			
SSH6.0X40**	75128	6.0	40	10	23	PT	T-30 / SW-10	100
SSH6.0X50**	75129	6.0	50	10	33	PT	T-30 / SW-10	100
SSH6.0X60**	75130	6.0	60	10	42	PT	T-30 / SW-10	100
SSH6.0X75**	75131	6.0	75	10	42	PTM	T-30 / SW-10	100
SSH6.0X90**	75132	6.0	90	10	42	PTM	T-30 / SW-10	100
SSH6.0X120**	75133	6.0	120	10	75	PTM	T-30 / SW-10	100
SSH8.0X40	75134	8.0	40	13	Full thread	FT	T-40 / SW-13	50
SSH8.0X50	75135	8.0	50	13	Full thread	FT	T-40 / SW-13	50
SSH8.0X60	75136	8.0	60	13	42	PT	T-40 / SW-13	50
SSH8.0X80	75137	8.0	80	13	42	PTM	T-40 / SW-13	50
SSH8.0X90	75138	8.0	90	13	42	PTM	T-40 / SW-13	50
SSH8.0X100	75139	8.0	100	13	55	PTM	T-40 / SW-13	50
SSH8.0X120	75140	8.0	120	13	85	PTM	T-40 / SW-13	50
SSH8.0X140	75141	8.0	140	13	85	PTM	T-40 / SW-13	50
SSH8.0X160	75142	8.0	160	13	110	PTM	T-40 / SW-13	50
SSH8.0X180	75143	8.0	180	13	110	PTM	T-40 / SW-13	50
SSH8.0X200	75144	8.0	200	13	110	PTM	T-40 / SW-13	50
SSH8.0X240	75145	8.0	240	13	110	PTM	T-40 / SW-13	50
SSH8.0X260	75146	8.0	260	13	110	PTM	T-40 / SW-13	50
SSH8.0X280	75147	8.0	280	13	110	PTM	T-40 / SW-13	50
SSH8.0X300	75148	8.0	300	13	110	PTM	T-40 / SW-13	50
SSH10.0X40***	75149	10.0	40	15	Full thread	FT	T-40 / SW-15	50
SSH10.0X50	75150	10.0	50	15	Full thread	FT	T-40 / SW-15	50
SSH10.0X60	75151	10.0	60	15	42	PT	T-40 / SW-15	50
SSH10.0X80	75152	10.0	80	15	42	PTM	T-40 / SW-15	50
SSH10.0X90	75153	10.0	90	15	42	PTM	T-40 / SW-15	50
SSH10.0X100	75154	10.0	100	15	55	PTM	T-40 / SW-15	50
SSH10.0X120	75155	10.0	120	15	85	PTM	T-40 / SW-15	50
SSH10.0X140	75156	10.0	140	15	85	PTM	T-40 / SW-15	50
SSH10.0X160	75157	10.0	160	15	110	PTM	T-40 / SW-15	50
SSH10.0X180	75158	10.0	180	15	110	PTM	T-40 / SW-15	50
SSH10.0X200	75159	10.0	200	15	110	PTM	T-40 / SW-15	50
SSH10.0X240	75160	10.0	240	15	125	PTM	T-40 / SW-15	50
SSH10.0X280	75161	10.0	280	15	125	PTM	T-40 / SW-15	50
SSH12.0X60	75162	12.0	60	17	Full thread	FT	T-40 / SW-17	25
SSH12.0X80	75163	12.0	80	17	42	PTM	T-40 / SW-17	25
SSH12.0X90	75164	12.0	90	17	42	PTM	T-40 / SW-17	25
SSH12.0X100	75165	12.0	100	17	55	PTM	T-40 / SW-17	25
SSH12.0X120	75166	12.0	120	17	85	PTM	T-40 / SW-17	25
SSH12.0X140	75167	12.0	140	17	85	PTM	T-40 / SW-17	25
SSH12.0X160	75168	12.0	160	17	110	PTM	T-40 / SW-17	25
SSH12.0X180	75169	12.0	180	17	110	PTM	T-40 / SW-17	25
SSH12.0X200	75170	12.0	200	17	110	PTM	T-40 / SW-17	25

*) FT = Full thread, PT = Partial thread, PTM = Partial thread with milling thread.

**) Different head design (see page 16).

***) Not CE-marked

For additional technical data, such as load-bearing capacities, installation data and more, visit our website www.strongtie.eu.

Solid-Drive™ SSF Flat Round Head CONNECTOR Screw

The Solid-Drive™ SSF is used together with connectors where high load capability is required. The conical shape under the head makes a perfect fitting to the connector hole, creating a firm assembly. Suitable for exterior use.

The cut point type 17 prevents cracking, and the milling thread and serrated thread reduce the insertion torque. SSF has a round flat head with 6 lobe drive, creating an aesthetically improved end-result.

Application

- Metal-to-Wood Connections

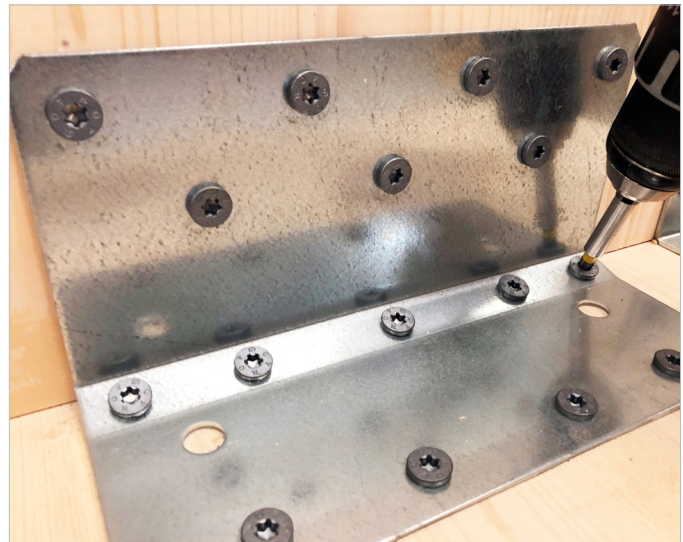

SSF screws fastening of AB255SSH angle bracket.



ETA-21/0670

Features

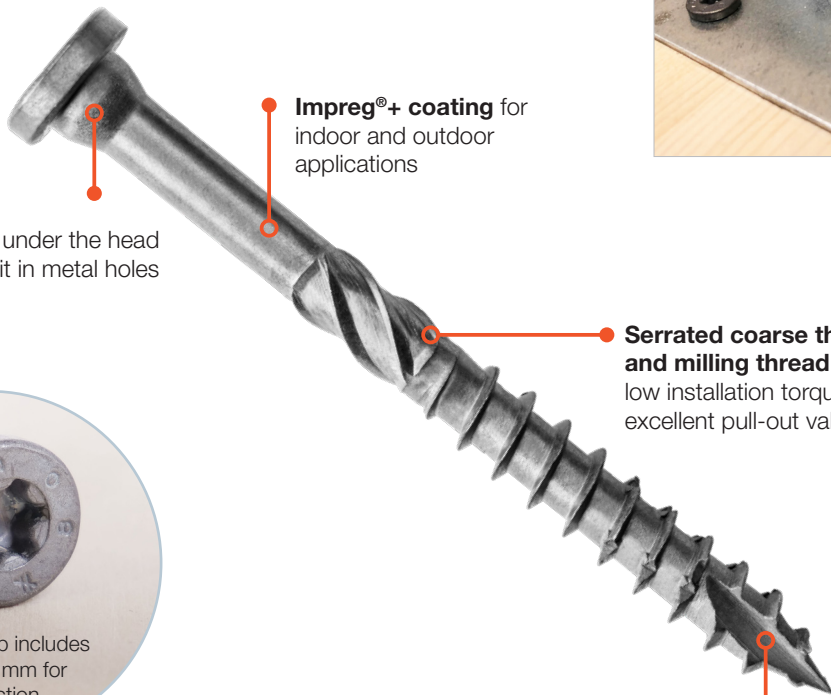

Conical shape under the head for maximum fit in metal holes

Impreg®+ coating for indoor and outdoor applications

Serrated coarse thread and milling thread for low installation torque and excellent pull-out values

Type 17 cut point reduces the risk of wood splitting during the installation



Deep 6-lobe recess provides improved control and greater bit life



SSF screws fastening of AB255SSH angle bracket.



ETA-21/0670

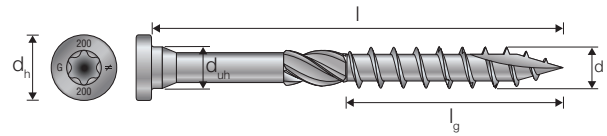

SSF Impreg®+

Model No.	Item code	Dimensions [mm]				Thread*	Bit	
		d / d _{uh}	l	d _h	l _g			
SSF8.0X40	75185	8.0	40	13	Full thread	FT	T-40	50
SSF8.0X60	75186	8.0	60	13	42	PT	T-40	50
SSF8.0X80	75187	8.0	80	13	42	PTM	T-40	50
SSF10.0X40*)	75188	10.0	40	15	Full thread	FT	T-40	50
SSF10.0X60	75189	10.0	60	15	42	PT	T-40	50
SSF10.0X80	75190	10.0	80	15	42	PTM	T-40	50

*)FT = Full thread, PT = Partial thread, PTM = Partial thread with milling thread.

*) Not CE-marked

For additional technical data, such as load-bearing capacities, installation data and more, visit our website www.strongtie.eu.

Tested and approved fastening solutions for installing Simpson Strong-Tie® connectors to wood

Simpson Strong-Tie® offers the most high-performance steel connectors on the market, and they have proven most effective when paired with our tested premium structural fasteners. Together, fasteners and connectors create a system, that helps ensure the strength of your connection and the safety of your structures.

We provide fastener recommendations for all of our connectors. Variables such as application, environment and load requirements all play a part in how we determine the appropriate fastener type, length, diameter, and finish. Be sure to match the metal and finish of you fastener to that of your connector, since mixing different materials and coatings might create what is known as galvanic corrosion.

We highly recommend to consult our wood connector catalogue or website to determine exactly which fasteners should be used with your connectors.

The Strength of the System

Simpson Strong-Tie® connectors are designed to help you build safer, stronger structures. In our catalogues and on our website we publish the load-bearing capacities of our connectors for each of the different applications where they are applicable.

Together, fasteners and connectors create a system, where the different parts cannot be replaced. So, if you want to be able to document the load-bearing capacities of the structures you build, it is essential that you use the right fasteners to install your connectors.

To learn more, go to strongtie.eu



Always use Simpson Strong-Tie **FASTENERS** to install Simpson Strong-Tie **CONNECTORS**



There is no equal

Solid-Drive™

TTSFS/TTZNFS/TTUFS Structural Countersunk WOOD Screws

TTSFS, TTZNFS and TTUFS screws are countersunk screws for structural wood applications. The screws have a serrated thread to reduce the resistance when driving and a type 17 cut point which reduced the risk of wood splitting. 80 mm or longer variants have an additional milling thread to further reduce the resistance.

Application

- Wood-to-Wood Connections



Ledger fastened with TTNFS screws.

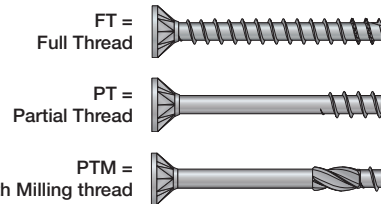
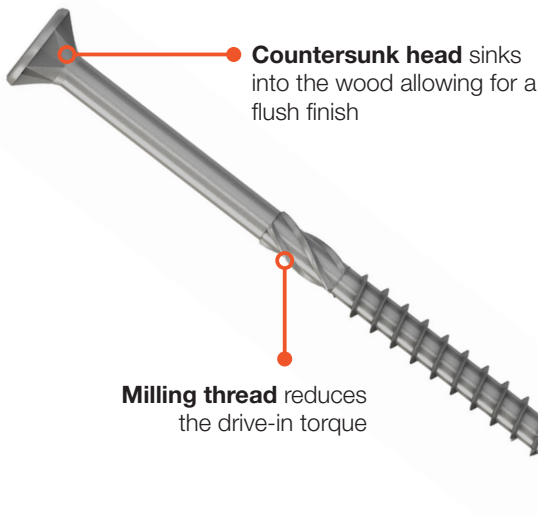

ETA-21/0670

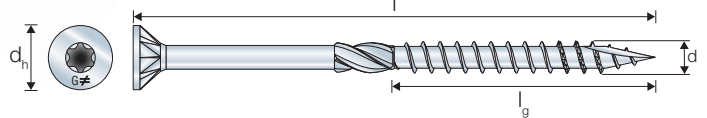

TTSFS Stainless Steel A4

Model No.	Item code	Dimensions [mm]				t _{hix}	Thread	Bit	
		d	l	d _h	l _g				
TTSFS5.0X60	74446	5.0	60	9.5	32	28	PT	T-25	100
TTSFS5.0X70	74447	5.0	70	9.5	35	35	PT	T-25	100
TTSFS5.0X80	74448	5.0	80	9.5	40	40	PTM	T-25	100
TTSFS5.0X90	74449	5.0	90	9.5	45	45	PTM	T-25	100
TTSFS5.0X100	74444	5.0	100	9.5	55	45	PTM	T-25	100
TTSFS5.0X120	74445	5.0	120	9.5	60	60	PTM	T-25	100
TTSFS6.0X70	74473	6.0	70	11.6	35	35	PT	T-30	100
TTSFS6.0X80	74474	6.0	80	11.6	40	40	PTM	T-30	100
TTSFS6.0X90	74475	6.0	90	11.6	45	45	PTM	T-30	100
TTSFS6.0X100	74450	6.0	100	11.6	55	45	PTM	T-30	100
TTSFS6.0X120	74471	6.0	120	11.6	60	60	PTM	T-30	100
TTSFS6.0X140	74472	6.0	140	11.6	65	75	PTM	T-30	100

For additional technical data, such as load-bearing capacities, installation data and more, visit our website www.strongtie.eu.



ETA-21/0670

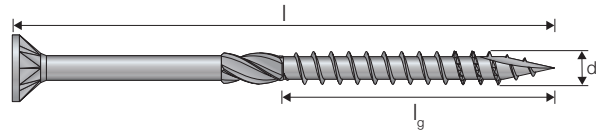
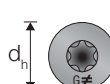

TTZNFS Impreg®+

Model No.	Item code	Dimensions [mm]				Thread	Bit	
		d	l	d _h	l _g			
TTZNFS4.5X25	74481	4.5	25	8.4	20	FT	T-20	200
TTZNFS4.5X30	74482	4.5	30	8.4	25	FT	T-20	200
TTZNFS4.5X35	76582	4.5	35	8.4	30	FT	T-20	200
TTZNFS4.5X40	74483	4.5	40	8.4	35	PT	T-20	200
TTZNFS4.5X45	76561	4.5	45	8.4	29	PT	T-20	200
TTZNFS4.5X50	74484	4.5	50	8.4	30	PT	T-20	200
TTZNFS4.5X60	74485	4.5	60	8.4	35	PT	T-20	200
TTZNFS4.5X70	74486	4.5	70	8.4	40	PT	T-20	100
TTZNFS4.5X80	76563	4.5	80	8.4	50	PTM	T-20	100
TTZNFS5.0X30	76535	5.0	30	9.5	25	FT	T-20	200
TTZNFS5.0X40	76536	5.0	40	9.5	35	FT	T-20	200
TTZNFS 5.0X50	74489	5.0	50	9.5	30	PT	T-25	200
TTZNFS 5.0X60	74490	5.0	60	9.5	35	PT	T-25	200
TTZNFS5.0X70	74491	5.0	70	9.5	40	PT	T-25	100
	74492	5.0	70	9.5	40	PT	T-25	750
TTZNFS5.0X80	74493	5.0	80	9.5	40	PTM	T-25	100
	74494	5.0	80	9.5	40	PTM	T-25	650
TTZNFS5.0X90	74495	5.0	90	9.5	45	PTM	T-25	100
	74496	5.0	90	9.5	45	PTM	T-25	450
TTZNFS5.0X100	74487	5.0	100	9.5	60	PTM	T-25	100
	74510	5.0	100	9.5	60	PTM	T-25	450
TTZNFS5.0X120	74488	5.0	120	9.5	60	PTM	T-25	100
TTZNFS6.0X40	76566	6.0	40	11.6	34	FT	T-30	200
TTZNFS6.0X50	76567	6.0	50	11.6	30	PT	T-30	200
TTZNFS6.0X60	74504	6.0	60	11.6	35	PT	T-30	200
TTZNFS6.0X70	74505	6.0	70	11.6	40	PT	T-30	100
TTZNFS6.0X80	74506	6.0	80	11.6	40	PTM	T-30	100
	74507	6.0	80	11.6	40	PTM	T-30	450
TTZNFS6.0X90	74508	6.0	90	11.6	45	PTM	T-30	100
	74509	6.0	90	11.6	45	PTM	T-30	450
TTZNFS6.0X100	74497	6.0	100	11.6	60	PTM	T-30	100
	74498	6.0	100	11.6	60	PTM	T-30	300
TTZNFS6.0X120	74499	6.0	120	11.6	70	PTM	T-30	100
	74500	6.0	120	11.6	70	PTM	T-30	250
TTZNFS6.0X140	74501	6.0	140	11.6	70	PTM	T-30	100
TTZNFS6.0X160	74502	6.0	160	11.6	70	PTM	T-30	100
TTZNFS6.0X180	74503	6.0	180	11.6	70	PTM	T-30	100

For additional technical data, such as load-bearing capacities, installation data and more, visit our website www.strongtie.eu.



ETA-21/0670

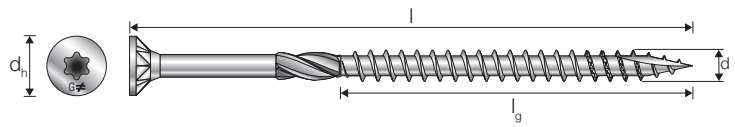

TTUFS Electro Galvanised

Model No.	Item code	Dimensions [mm]				Thread	Bit	
		d	l	d _h	l _g			
TTUFS4.5X25	74434	4.5	25	8.4	20	FT	T-20	200
TTUFS4.5X30	74435	4.5	30	8.4	25	FT	T-20	200
TTUFS4.5X35	74436	4.5	35	8.4	30	FT	T-20	200
TTUFS4.5X40	74437	4.5	40	8.4	35	FT	T-20	200
TTUFS4.5X45	74438	4.5	45	8.4	29	PT	T-20	200
TTUFS4.5X50	74439	4.5	50	8.4	30	PT	T-20	200
TTUFS4.5X60	74440	4.5	60	8.4	35	PT	T-20	200
TTUFS4.5X70	74441	4.5	70	8.4	40	PT	T-20	100
TTUFS4.5X80	74442	4.5	80	8.4	50	PTM	T-20	100
TTUFS5.0X30	74373	5.0	30	9.5	25	FT	T-25	200
TTUFS5.0X40	74374	5.0	40	9.5	35	FT	T-25	200
TTUFS5.0X50	74375	5.0	50	9.5	30	PT	T-25	200
TTUFS5.0X60	74376	5.0	60	9.5	35	PT	T-25	200
TTUFS5.0X70	74377	5.0	70	9.5	40	PT	T-25	100
TTUFS5.0X80	74378	5.0	80	9.5	40	PTM	T-25	100
TTUFS5.0X90	74379	5.0	90	9.5	45	PTM	T-25	100
TTUFS5.0X100	74443	5.0	100	9.5	60	PTM	T-25	100
TTUFS5.0X120	74372	5.0	120	9.5	60	PTM	T-25	100
TTUFS6.0X40	74455	6.0	40	11.6	34	FT	T-30	200
TTUFS6.0X50	74457	6.0	50	11.6	30	PT	T-30	200
TTUFS6.0X60	74458	6.0	60	11.6	35	PT	T-30	200
TTUFS6.0X70	74459	6.0	70	11.6	40	PT	T-30	100
TTUFS6.0X80	74460	6.0	80	11.6	40	PTM	T-30	100
TTUFS6.0X90	74461	6.0	90	11.6	45	PTM	T-30	100
TTUFS6.0X100	74380	6.0	100	11.6	60	PTM	T-30	100
TTUFS6.0X120	74451	6.0	120	11.6	70	PTM	T-30	100
TTUFS6.0X140	74452	6.0	140	11.6	70	PTM	T-30	100
TTUFS6.0X160	74453	6.0	160	11.6	70	PTM	T-30	100
TTUFS6.0X180	74454	6.0	180	11.6	70	PTM	T-30	100

For additional technical data, such as load-bearing capacities, installation data and more, visit our website www.strongtie.eu.

Solid-Drive™

TTZNFP/TTUFP Structural Pan Head WOOD Screws

TTZNFP / TTUFP screws have a 6 lobe drive and type 17 point which drives the screw smoothly into the wood-work and prevents splitting.

All screws have saw thread that reduces torque. Serrations under the head help the screw to grip the material.

Application

- Wood-to-Wood Connections, Metal-to-Wood Connections



ETA-21/0670

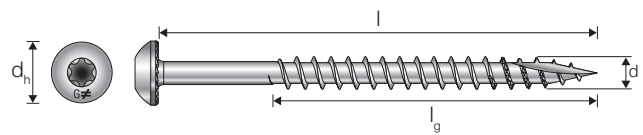

TTUFP Electro Galvanised

Model No.	Item code	Dimensions [mm]				Thread	Bit	Box
		d	l	d _h	l _g			
TTUFP5.0X30	74525	5.0	30	9.7	26	FT	T-25	200
TTUFP5.0X40	74526	5.0	40	9.7	36	FT	T-25	200
TTUFP5.0X50	74527	5.0	50	9.7	30	PT	T-25	200
TTUFP5.0X60	74528	5.0	60	9.7	35	PT	T-25	200
TTUFP5.0X70	74529	5.0	70	9.7	40	PT	T-25	100
TTUFP5.0X80	74530	5.0	80	9.7	50	PT	T-25	100
TTUFP6.0X40	74532	6.0	40	11.7	35	FT	T-30	100
TTUFP6.0X50	74533	6.0	50	11.7	30	PT	T-30	200
TTUFP6.0X60	74534	6.0	60	11.7	35	PT	T-30	200
TTUFP6.0X70	74535	6.0	70	11.7	40	PT	T-30	100
TTUFP6.0X80	74536	6.0	80	11.7	50	PT	T-30	100
TTUFP6.0X100	74531	6.0	100	11.7	60	PT	T-30	100



ETA-21/0670

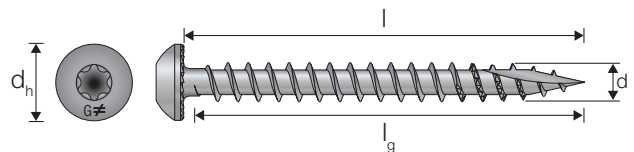

TTZNFP Impreg®+

Model No.	Item code	Dimensions [mm]				Thread	Bit	Box
		d	l	d _h	l _g			
TTZNFP5.0X40	74540	5.0	40	9.7	36	FT	T-25	200
TTZNFP5.0X50	74541	5.0	50	9.7	30	FT	T-25	200
TTZNFP5.0X60	74542	5.0	60	9.7	35	FT	T-25	200
TTZNFP5.0X70	74543	5.0	70	9.7	40	FT	T-25	100
TTZNFP5.0X80	74544	5.0	80	9.7	50	FT	T-25	100
TTZNFP6.0X60	74546	6.0	60	11.7	35	PT	T-30	200
TTZNFP6.0X80	74547	6.0	80	11.7	50	PT	T-30	100
TTZNFP6.0X100	74545	6.0	100	11.7	60	PT	T-30	100

For additional technical data, such as load-bearing capacities, installation data and more, visit our website www.strongtie.eu.

Solid-Drive™ ESCRFTC Structural Full Threaded Countersunk WOOD Screw

The Solid-Drive® ESCRFTC wood screw is a structural fastener available in a variety of lengths and is designed for cross-laminated timber (CLT), glulam construction, beam reinforcement and general interior applications.

ESCRFTC is a full threaded structural screws with a countersunk head. The half-cut point allows for fast starts in screwed installations.

Application

- CLT Wall-to-Wall, Floor-to-Floor, Panel-to-Beam
- Panel-to-Wall, Surface Spline, Lap Joint and Ledger Connections; General Timber Framing

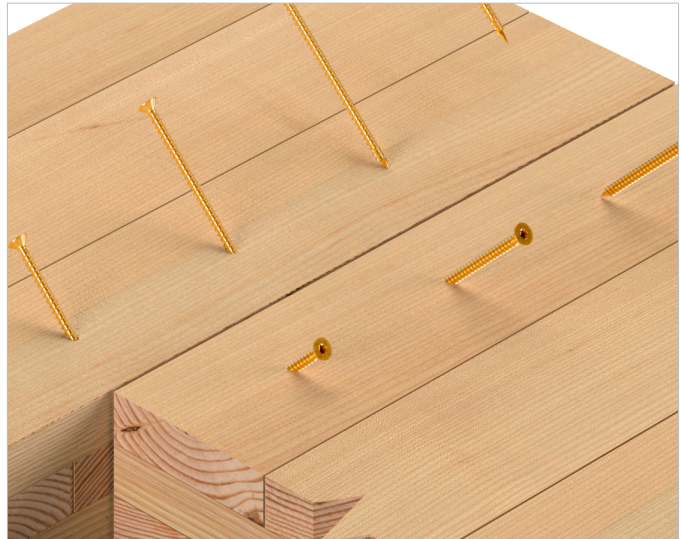

ESCRFTC screwed installation of CLT floor-to-floor.



ETA-13/0796

Features

Countersunk head with underhead nibs creates a flush finish

Yellow zinc coating for interior and dry applications

Half-cut point gives low installation torque and no pre-drilling is required

Full threaded for excellent pull-out values and high load-bearing capacities

Heavy-duty thread and shank provides strength and stability

Head stamp includes length in mm for inspection



Deep 6-lobe recess provides improved control and greater bit life

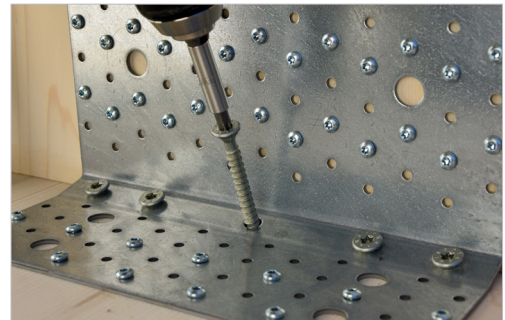

ESCRFTC screwed fastening of AB255HD angle bracket.



ETA-13/0796

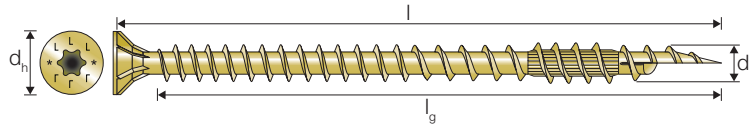

ESCRFTC Yellow Zinc Plated

Model No.	Dimensions [mm]				Bit	
	d	l	d _h	l _g		
ESCRFTC8.0X120	8.0	120	15.0	110	T-40	50
ESCRFTC8.0X140	8.0	140	15.0	130	T-40	50
ESCRFTC8.0X160	8.0	160	15.0	150	T-40	50
ESCRFTC8.0X180	8.0	180	15.0	170	T-40	50
ESCRFTC8.0X200	8.0	200	15.0	190	T-40	50
ESCRFTC8.0X220	8.0	220	15.0	210	T-40	50
ESCRFTC8.0X240	8.0	240	15.0	230	T-40	50
ESCRFTC8.0X260	8.0	260	15.0	250	T-40	50
ESCRFTC8.0X280	8.0	280	15.0	270	T-40	50
ESCRFTC8.0X300	8.0	300	15.0	290	T-40	50
ESCRFTC8.0X350	8.0	350	15.0	340	T-40	50
ESCRFTC8.0X400	8.0	400	15.0	390	T-40	50
ESCRFTC8.0X450	8.0	450	15.0	427	T-40	50
ESCRFTC10.0X120	10.0	120	18.5	108	T-50	50
ESCRFTC10.0X160	10.0	160	18.5	148	T-50	50
ESCRFTC10.0X180	10.0	180	18.5	168	T-50	50
ESCRFTC10.0X200	10.0	200	18.5	188	T-50	50
ESCRFTC10.0X220	10.0	220	18.5	208	T-50	50
ESCRFTC10.0X240	10.0	240	18.5	228	T-50	50
ESCRFTC10.0X260	10.0	260	18.5	248	T-50	50
ESCRFTC10.0X280	10.0	280	18.5	268	T-50	50
ESCRFTC10.0X300	10.0	300	18.5	288	T-50	50
ESCRFTC10.0X350	10.0	350	18.5	338	T-50	50
ESCRFTC10.0X400	10.0	400	18.5	388	T-50	50
ESCRFTC10.0X450	10.0	450	18.5	426	T-50	50
ESCRFTC12.0X200	12.0	200	20.0	180	T-50	25
ESCRFTC12.0X220	12.0	220	20.0	200	T-50	25
ESCRFTC12.0X240	12.0	240	20.0	220	T-50	25
ESCRFTC12.0X260	12.0	260	20.0	240	T-50	25
ESCRFTC12.0X280	12.0	280	20.0	260	T-50	25
ESCRFTC12.0X300	12.0	300	20.0	280	T-50	25
ESCRFTC12.0X350	12.0	350	20.0	330	T-50	25
ESCRFTC12.0X400	12.0	400	20.0	380	T-50	25
ESCRFTC12.0X450	12.0	450	20.0	430	T-50	25
ESCRFTC12.0X500	12.0	500	20.0	480	T-50	25
ESCRFTC12.0X600	12.0	600	20.0	580	T-50	25

For additional technical data, such as load-bearing capacities, installation data and more, visit our website www.strongtie.eu.

Solid-Drive™**ESCRFTZ/ESCRFT Structural Full Threaded Cylinder Head WOOD Screws**

The Solid-Drive® ESCRFTZ and ESCRFT wood screws are structural fasteners available in a variety of lengths and are designed for cross-laminated timber (CLT), glulam construction, beam reinforcement and general interior applications.

ESCRFTZ and ESCRFT are full threaded cylinder head structural screws. The version ESCRFTZ has a sharp point and ESCRFT has a half-cut point that allows for fast starts in scewed installations.

Application

- CLT Wall-to-Wall, Floor-to-Floor, Panel-to-Beam
- Panel-to-Wall, Surface Spline, Lap Joint and Ledger Connections; General Timber Framing



ETA-13/0796

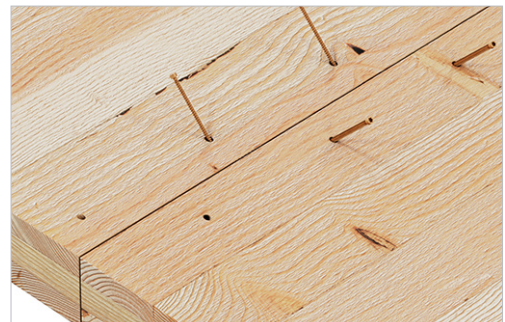
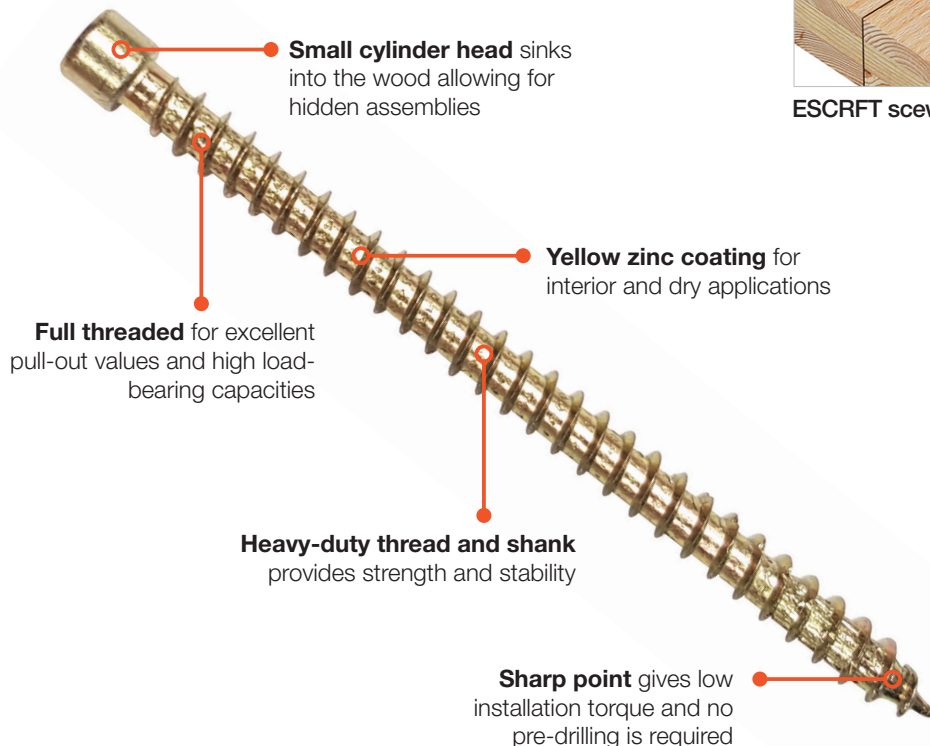

ESCRFTZ screws installed into a CLT floor on joists.

Features

ESCRFT scewed installation of CLT floor-to-floor.



ESCRFT is supplied with a **Half-cut point** which makes it easy to get a grip in the wood.



ETA-13/0796

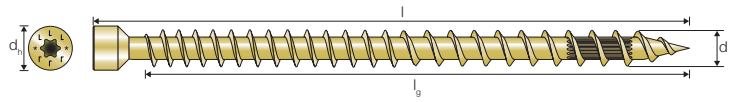

ESCRFTZ Yellow Zinc Plated

Model No.	Dimensions [mm]				Bit	
	d	l	d _h	l _g		
ESCRFTZ8.0X120	8.0	120	10.2	110	T-40	50
ESCRFTZ8.0X140	8.0	140	10.2	130	T-40	50
ESCRFTZ8.0X160	8.0	160	10.2	150	T-40	50
ESCRFTZ8.0X180	8.0	180	10.2	170	T-40	50
ESCRFTZ8.0X200	8.0	200	10.2	190	T-40	50
ESCRFTZ8.0X220	8.0	220	10.2	210	T-40	50
ESCRFTZ8.0X240	8.0	240	10.2	230	T-40	50
ESCRFTZ8.0X260	8.0	260	10.2	250	T-40	50
ESCRFTZ8.0X280	8.0	280	10.2	270	T-40	50
ESCRFTZ8.0X300	8.0	300	10.2	290	T-40	50
ESCRFTZ8.0X350	8.0	350	10.2	340	T-40	50
ESCRFTZ8.0X400	8.0	400	10.2	390	T-40	50



ETA-13/0796

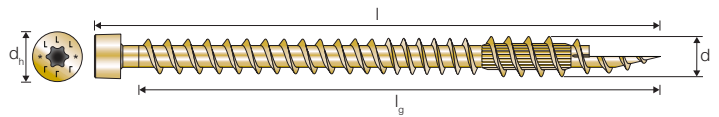

ESCRFT Yellow Zinc Plated

Model No.	Dimensions [mm]				Bit	
	d	l	d _h	l _g		
ESCRFT10.0X450	10.0	450	13.4	426	T-50	25
ESCRFT10.0X500	10.0	500	13.4	476	T-50	25
ESCRFT10.0X600	10.0	600	13.4	576	T-50	25
ESCRFT10.0X800	10.0	800	13.4	776	T-50	15
ESCRFT10.0X1000	10.0	1000	13.4	976	T-50	15

For additional technical data, such as load-bearing capacities, installation data and more, visit our website www.strongtie.eu.

Solid-Drive™ ESCRT2R Structural Roof Insulation WOOD Screw

The ETA approved ESCRT2R screw is the ideal fixing option for roof insulation. The screw can absorb shear and compressive forces and by doing so, the insulation material is pressed significantly less to the background, thereby improving the insulation performance.

ESCRT2R screws are suitable for inclined and angled installations. Use the GSCREW screw guide to ensure that screws are installed with the correct angle into the timber.

Application

- Fixing of top roof insulation to wood



ETA-13/0796

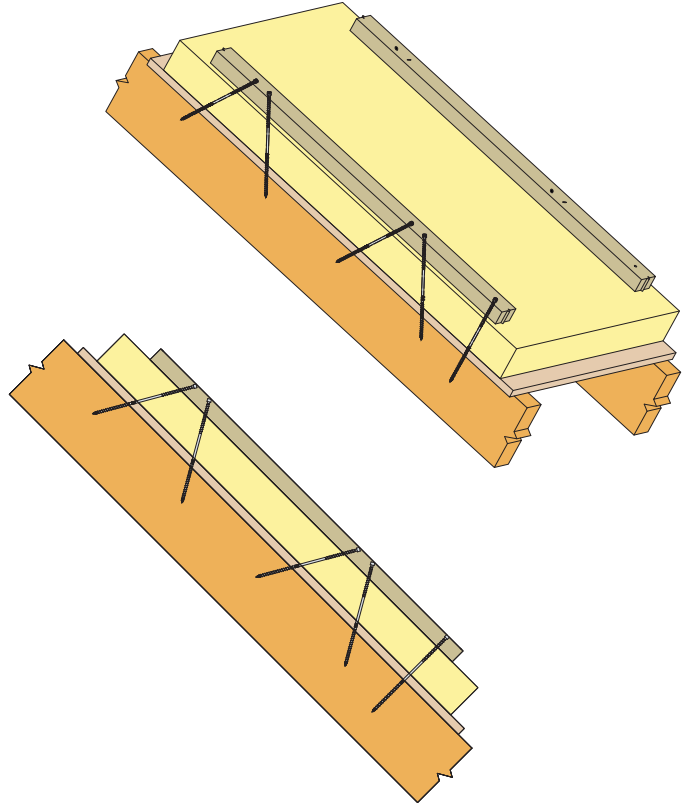

Features

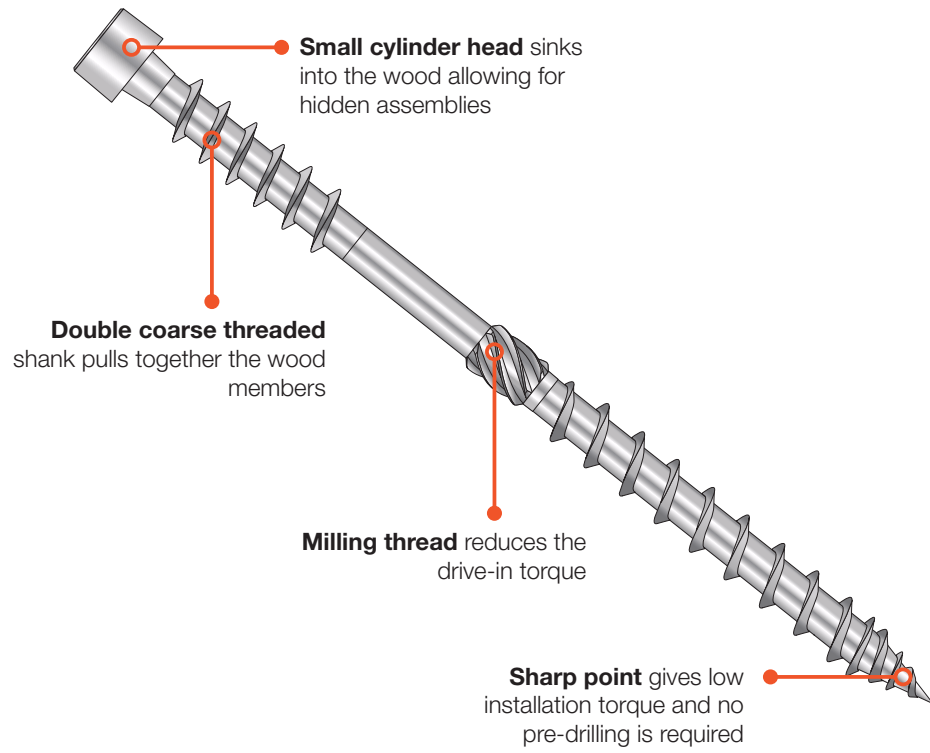

Use the **GSCREW** screw guide to install ESCRT2R in inclined and angled roof insulation installations.



ETA-13/0796

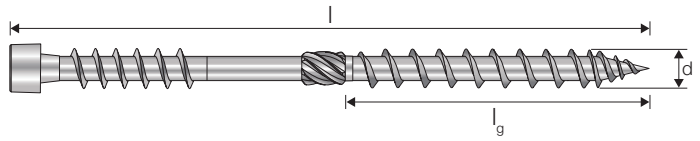
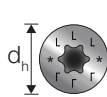

ESCRT2R Electro Galvanised

Model No.	Dimensions [mm]				Bit	
	d	l	d _h	l _g		
ESCRT2R8.0X240	8.0	240	10.2	84	T-40	50
ESCRT2R8.0X260	8.0	260	10.2	100	T-40	50
ESCRT2R8.0X280	8.0	280	10.2	100	T-40	50
ESCRT2R8.0X300	8.0	300	10.2	100	T-40	50
ESCRT2R8.0X320	8.0	320	10.2	100	T-40	50
ESCRT2R8.0X340	8.0	340	10.2	100	T-40	50
ESCRT2R8.0X360	8.0	360	10.2	100	T-40	50
ESCRT2R8.0X400	8.0	400	10.2	100	T-40	50
ESCRT2R8.0X450	8.0	450	10.2	100	T-40	50

For additional technical data, such as load-bearing capacities, installation data and more, visit our website www.strongtie.eu.

Structural screw guide for 45° and 60° inclined installations

The GSCREW4560 screw guide assists with the installation of any structural screws with a diameter between 8 and 12 mm with a skew angle of 45° or 60°.

The screw guide is suitable for the installation of full threaded screws or double threaded screws in structural timber, LVL, glulam or CLT applications or for fastening roof insulation, where 45° or 60° angled installations are common. However, it can also be used for any type of application as long as the screw is longer than 100 mm for a 45° configuration and longer than 140 mm for a 60° configuration.

This screw guide allows for easy installation of the screws at the required angle. [See more on pages 38-39.](#)

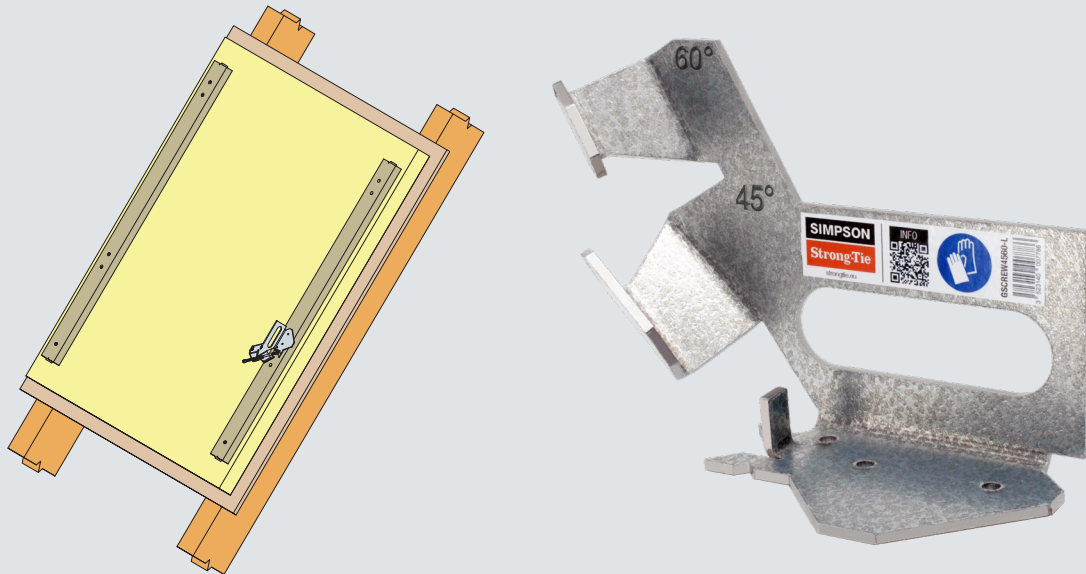

Solid-Drive™ ESCR Structural Washer Head WOOD Screw

The Solid-Drive® ESCR partially threaded washer head wood screw is a structural fastener available in a variety of dimensions and is designed for cross-laminated timber (CLT) and glulam construction, as well as general interior wood applications.

These partially-threaded, 6.0, 8.0 and 10.0 diameter [mm] structural fasteners are designed to pull structural members together with superb holding power and excellent load capacity. The large washer head provides extreme pull-through resistance while allowing the wood members to close up firmly. Predrilling is not typically required. For interior and dry applications only.

Application

- CLT Wall-to-Wall, Floor-to-Floor, Panel-to-Beam
- Panel-to-Wall, Surface Spline, Lap Joint and Ledger Connections; General Timber Framing



ESCR screws installed into a T-connection between two walls.



ESCR screw installed into a CLT floor-to-wall connection.

Features

Washer head with creates high pull-through resistance

Yellow zinc coating for interior and dry applications

Heavy-duty thread and shank provides strength and stability

Milling thread reduces the drive-in torque



Deep 6-lobe recess provides improved control and greater bit life

© SIMPSON STRONG-TIE® F-EU-SOLIDDRIVE-2022



ETA-13/0796

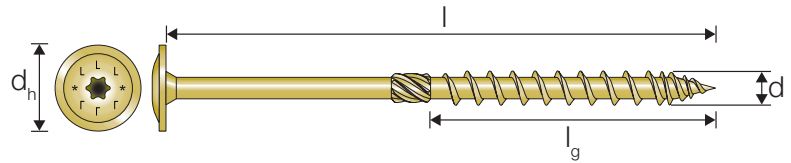

ESCR Yellow Zinc Plated

Model No.	Dimensions [mm]				Bit	
	d	l	d _h	l _g		
ESCR6.0X60	6.0	60	14.0	36	T-30	100
ESCR6.0X80	6.0	80	14.0	48	T-30	100
ESCR6.0X100	6.0	100	14.0	48	T-30	100
ESCR6.0X120	6.0	120	14.0	64	T-30	100
ESCR6.0X140	6.0	140	14.0	64	T-30	100
ESCR6.0X160	6.0	160	14.0	64	T-30	100
ESCR6.0X180	6.0	180	14.0	64	T-30	100
ESCR6.0X200	6.0	200	14.0	64	T-30	100
ESCR8.0X80	8.0	80	20.0	54	T-40	50
ESCR8.0X100	8.0	100	20.0	54	T-40	50
ESCR8.0X120	8.0	120	20.0	54	T-40	50
ESCR8.0X140	8.0	140	20.0	84	T-40	50
ESCR8.0X160	8.0	160	20.0	84	T-40	50
ESCR8.0X180	8.0	180	20.0	100	T-40	50
ESCR8.0X200	8.0	200	20.0	100	T-40	50
ESCR8.0X220	8.0	220	20.0	100	T-40	50
ESCR8.0X240	8.0	240	20.0	100	T-40	50
ESCR8.0X260	8.0	260	20.0	100	T-40	50
ESCR8.0X280	8.0	280	20.0	100	T-40	50
ESCR8.0X300	8.0	300	20.0	100	T-40	50
ESCR8.0X320	8.0	320	20.0	100	T-40	50
ESCR8.0X340	8.0	340	20.0	100	T-40	50
ESCR8.0X360	8.0	360	20.0	100	T-40	50
ESCR8.0X380	8.0	380	20.0	100	T-40	50
ESCR8.0X400	8.0	400	20.0	100	T-40	50

Model No.	Dimensions [mm]				Bit	
	d	l	d _h	l _g		
ESCR10.0X100	10.0	100	25.0	60	T-50	25
ESCR10.0X120	10.0	120	25.0	60	T-50	25
ESCR10.0X140	10.0	140	25.0	60	T-50	25
ESCR10.0X160	10.0	160	25.0	100	T-50	25
ESCR10.0X180	10.0	180	25.0	100	T-50	25
ESCR10.0X200	10.0	200	25.0	100	T-50	25
ESCR10.0X220	10.0	220	25.0	100	T-50	25
ESCR10.0X240	10.0	240	25.0	100	T-50	25
ESCR10.0X260	10.0	260	25.0	100	T-50	25
ESCR10.0X280	10.0	280	25.0	100	T-50	25
ESCR10.0X300	10.0	300	25.0	100	T-50	25
ESCR10.0X320	10.0	320	25.0	100	T-50	25
ESCR10.0X340	10.0	340	25.0	100	T-50	25
ESCR10.0X360	10.0	360	25.0	100	T-50	25
ESCR10.0X380	10.0	380	25.0	100	T-50	25
ESCR10.0X400	10.0	400	25.0	100	T-50	25

For additional technical data, such as load-bearing capacities, installation data and more, visit our website www.strongtie.eu.

Solid-Drive™ ESCRC Structural Countersunk WOOD Screw

The Solid-Drive® ESCRC partially threaded wood screw is a structural fastener available in a variety of dimensions and is designed for cross-laminated timber (CLT) and glulam construction, as well as general interior wood applications.

These partially-threaded, 6.0, 8.0 and 10.0 diameter [mm] structural fasteners are designed to pull structural members together with superb holding power and excellent load capacity. The countersunk head and underhead nibs provide for clean countersinking, flush with the surface. Predrilling is not typically required. For interior and dry applications only.

Application

- CLT Wall-to-Wall, Floor-to-Floor, Panel-to-Beam
- Panel-to-Wall, Surface Spline, Lap Joint and Ledger Connections; General Timber Framing

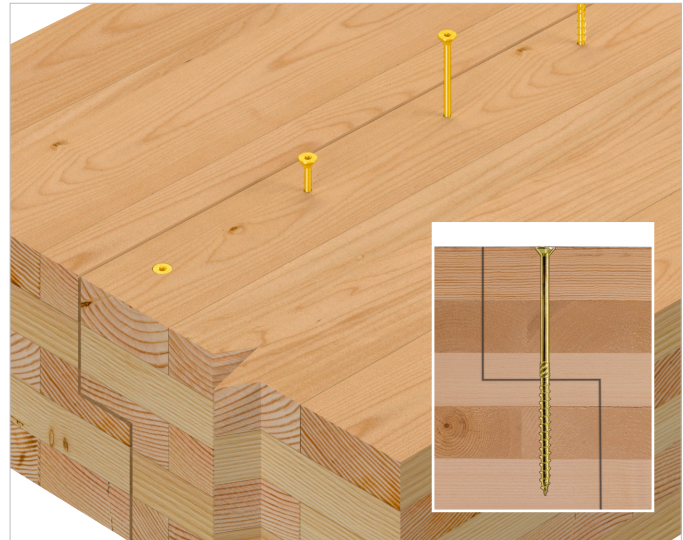

ESCRC screws installed into a CLT lap joint.



ETA-13/0796

Features

Countersunk head with underhead nibs creates a flush finish

Yellow zinc coating for interior and dry applications

Milling thread reduces the drive-in torque

Heavy-duty thread and shank provides strength and stability



Head stamp includes length in mm for inspection

Deep 6-lobe recess provides improved control and greater bit life



ESCRC screw installed into a CLT spline.



ETA-13/0796

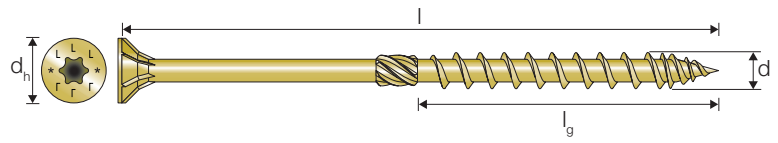

ESCRC Yellow Zinc Plated

Model No.	Dimensions [mm]				Bit	Box
	d	l	d _h	l _g		
ESCRC5.0X50	5.0	50	10.0	30	T-25	250
ESCRC5.0X60	5.0	60	10.0	30	T-25	250
ESCRC5.0X70	5.0	70	10.0	37	T-25	200
ESCRC5.0X80	5.0	80	10.0	37	T-25	200
ESCRC5.0X90	5.0	90	10.0	55	T-25	200
ESCRC6.0X60	6.0	60	12.0	60	T-30	200
ESCRC6.0X70	6.0	70	12.0	36	T-30	200
ESCRC6.0X80	6.0	80	12.0	48	T-30	100
ESCRC6.0X90	6.0	90	12.0	48	T-30	100
ESCRC6.0X100	6.0	100	12.0	48	T-30	100
ESCRC6.0X120	6.0	120	12.0	64	T-30	100
ESCRC6.0X130	6.0	130	12.0	64	T-30	100
ESCRC6.0X140	6.0	140	12.0	64	T-30	100
ESCRC6.0X150	6.0	150	12.0	64	T-30	100
ESCRC6.0X160	6.0	160	12.0	64	T-30	100
ESCRC6.0X180	6.0	180	12.0	64	T-30	100
ESCRC6.0X200	6.0	200	12.0	64	T-30	100
ESCRC6.0X220	6.0	220	12.0	64	T-30	100
ESCRC6.0X240	6.0	240	12.0	64	T-30	100
ESCRC6.0X260	6.0	260	12.0	64	T-30	100
ESCRC6.0X280	6.0	280	12.0	64	T-30	100
ESCRC6.0X300	6.0	300	12.0	64	T-30	100

Item code	Dimensions [mm]				Bit	Box
	d	l	d _h	l _g		
ESCRC8.0X80	8.0	80	15.0	54	T-40	50
ESCRC8.0X100	8.0	100	15.0	54	T-40	50
ESCRC8.0X120	8.0	120	15.0	54	T-40	50
ESCRC8.0X140	8.0	140	15.0	84	T-40	50
ESCRC8.0X160	8.0	160	15.0	84	T-40	50
ESCRC8.0X180	8.0	180	15.0	100	T-40	50
ESCRC8.0X200	8.0	200	15.0	100	T-40	50
ESCRC8.0X220	8.0	220	15.0	100	T-40	50
ESCRC8.0X240	8.0	240	15.0	100	T-40	50
ESCRC8.0X260	8.0	260	15.0	100	T-40	50
ESCRC8.0X280	8.0	280	15.0	100	T-40	50
ESCRC8.0X300	8.0	300	15.0	100	T-40	50
ESCRC8.0X320	8.0	320	15.0	100	T-40	50
ESCRC8.0X340	8.0	340	15.0	100	T-40	50
ESCRC8.0X360	8.0	360	15.0	100	T-40	50
ESCRC8.0X380	8.0	380	15.0	100	T-40	50
ESCRC8.0X400	8.0	400	15.0	100	T-40	50
ESCRC10.0X120	10.0	120	18.5	60	T-40	50
ESCRC10.0X140	10.0	140	18.5	60	T-40	50
ESCRC10.0X160	10.0	160	18.5	100	T-40	50
ESCRC10.0X180	10.0	180	18.5	100	T-40	50
ESCRC10.0X200	10.0	200	18.5	100	T-40	50
ESCRC10.0X220	10.0	220	18.5	100	T-40	50
ESCRC10.0X240	10.0	240	18.5	100	T-40	50
ESCRC10.0X260	10.0	260	18.5	100	T-40	50
ESCRC10.0X280	10.0	280	18.5	100	T-40	50
ESCRC10.0X300	10.0	300	18.5	100	T-40	50
ESCRC10.0X320	10.0	320	18.5	100	T-40	50
ESCRC10.0X340	10.0	340	18.5	100	T-40	50
ESCRC10.0X360	10.0	360	18.5	100	T-40	50
ESCRC10.0X380	10.0	380	18.5	100	T-40	50
ESCRC10.0X400	10.0	400	18.5	100	T-40	50

For additional technical data, such as load-bearing capacities, installation data and more, visit our website www.strongtie.eu.

Solid-Drive™ CNA Connector Nail

The Solid-Drive CNA connector nail, which is supplied in many different lengths and sizes, loose and collated, is a fully documented ETA-approved fastener used for installing metal connectors to wood. Guaranteed load bearing capacities when using CNA nails to install Simpson Strong-Tie connectors.

Collated CNA

CNA is available in a variety of different collations and is compatible with many pneumatic and gas-driven tools on the market.

The collated nails are available as 34° plastic collated and 34° paper collated as well as 15° plastic coil collated.

Application

- Metal-to-Wood Connections

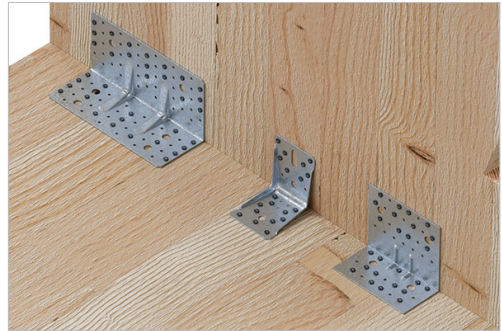

ETA-04/0013

Conical shape under the head for maximum fit in metal holes

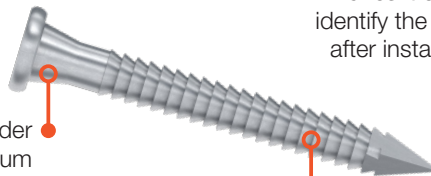

Ring-shank increases the pull-out resistance

Head-stamp makes it easy to identify the length after installation.



Compatible tools:

Tjep®	KA 4060 GAS 2G, KA 4060 GAS 3G, KA 2, KA 1, KA 1L, KA 4060 GAS
Senco®	GT60NN, MC60
Paslode®	F 250 S PP, PSN50NP
Basso®	A34/50MC-A, PN34-50-A1
Montana®	PN34-50A
Essve®	MCN 34/50

For exact nail length and diameter, see the product description for the tool.



ETA-04/0013

CNA34Z Electro Galvanised

Model No.	Item code	Dimensions [mm]				Box
		d	l	d _h	l _g	
CNA34G4.0X40	76166	4.0	40	7.0	30	1000
CNA34G4.0X50	76167	4.0	50	7.0	40	1000



ETA-04/0013

CNA34G Hot Dip Galvanised

Model No.	Item code	Dimensions [mm]				Box
		d	l	d _h	l _g	
CNA34G4.0X40	75652	4.0	40	7.0	30	1000
CNA34G4.0X50	75653	4.0	50	7.0	40	1000

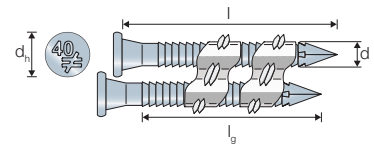
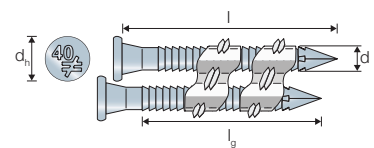

For additional technical data, such as load-bearing capacities, installation data and more, visit our website www.strongtie.eu.

Compatible tools:

Tjep®	KA 4060 GAS 2G*, KA 4060 GAS 3G*, KA 2*, KA 1**/, KA 1L**/, KA 4060 GAS*
Senco®	GT60NN*, MC60*
BEA®	R60-664E*
Paslode®	PPN50i**, F 250 S PP*, PSN50NP*
Basso®	A34/50MC-A**/, PN34/50-A1**/
Montana®	PN34-50A1**/
Essve®	MCN 34/50**/

For exact nail length and diameter, see the product description for the tool.

*Not compatible with 35mm nails
 **Not compatible with 60mm nails



ETA-04/0013



CNAPC34

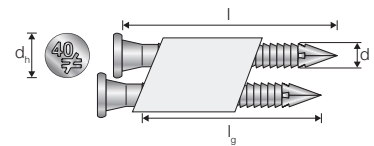

CNAPC34 Electro Galvanised

Model No.	Dimensions [mm]				Box
	d	l	d _h	l _g	
CNA4.0X35PC34	4.0	35	8.0	26	1500
CNA4.0X40PC34	4.0	40	8.0	31	1500
CNA4.0X50PC34	4.0	50	8.0	41	1000
CNA4.0X60PC34	4.0	60	8.0	51	1000

For additional technical data, such as load-bearing capacities, installation data and more, visit our website www.strongtie.eu.

Compatible tools:

Tjep®	BC 60
BEA®	AN 560 TC
Basso®	C33/65MC-A1
MAX®	HN65J
Montana®	CNP33-65MC

For exact nail length and diameter, see the product description for the tool.



ETA-04/0013

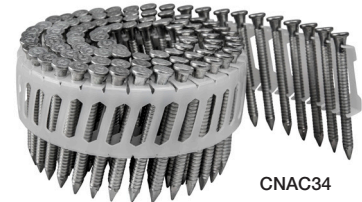

CNAC34

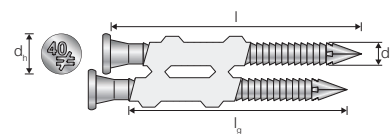

CNAC15 Electro Galvanised

Model No.	Item code	Dimensions [mm]				Box
		d	l	d _h	l _g	
CNAC15Z4.0X40	76138	4.0	40	7.0	31	1200
CNAC15Z4.0X50	76139	4.0	50	7.0	41	1200
CNAC15Z4.0X60	76140	4.0	60	7.0	51	1200



ETA-04/0013

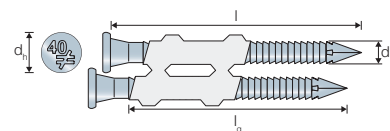

CNAC15-G Hot Dip Galvanised

Model No.	Item code	Dimensions [mm]				Box
		d	l	d _h	l _g	
CNAC15G4.0X40	76142	4.0	40	7.0	31	1200
CNAC15G4.0X50	76143	4.0	50	7.0	41	1200
CNAC15G4.0X60	76144	4.0	60	7.0	51	1200

For additional technical data, such as load-bearing capacities, installation data and more, visit our website www.strongtie.eu.

Solid-Drive™ CSA CONNECTOR Screw

The Solid-Drive™ CSA connector screw is developed for installing of Simpson Strong-Tie® connectors to wood, in order to obtain the published load bearing capacities.

The conical shape under the head secures fully contact to the connector, which increases the transfer of force. A fixed connection with larger cross-bearing capacity than for standard screws is obtained. The 6 lobe recess helps to fix the screw during insertion.

Quik Drive® collated for faster installations

With the Quik Drive collated CSA screws, Simpson Strong-Tie offers an extremely efficient method for installing connectors to CLT and glulam. CLT connectors often require many screws per installation, so by using the Quik Drive system, the installer can save considerable time.

Application

- Metal-to-Wood Connections



ETA-04/0013

Features

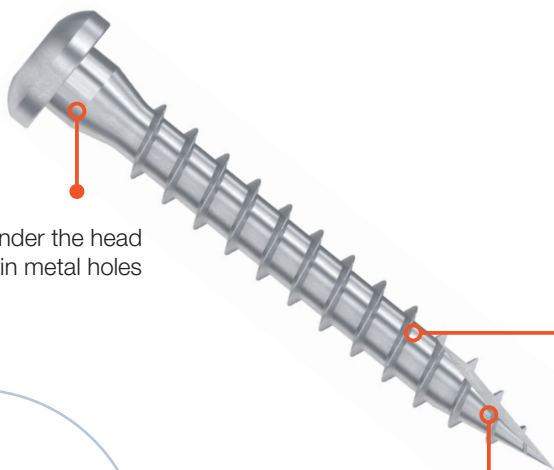

Conical shape under the head for maximum fit in metal holes

Available in a variety of **materials and coatings** securing a strong screw for all applications and environments

Type 17 cut point reduces the risk of wood splitting during the installation



Deep 6-lobe recess provides improved control and greater bit life

Quik Drive QDBPC50E system is designed specifically for installing CSA connector screws.

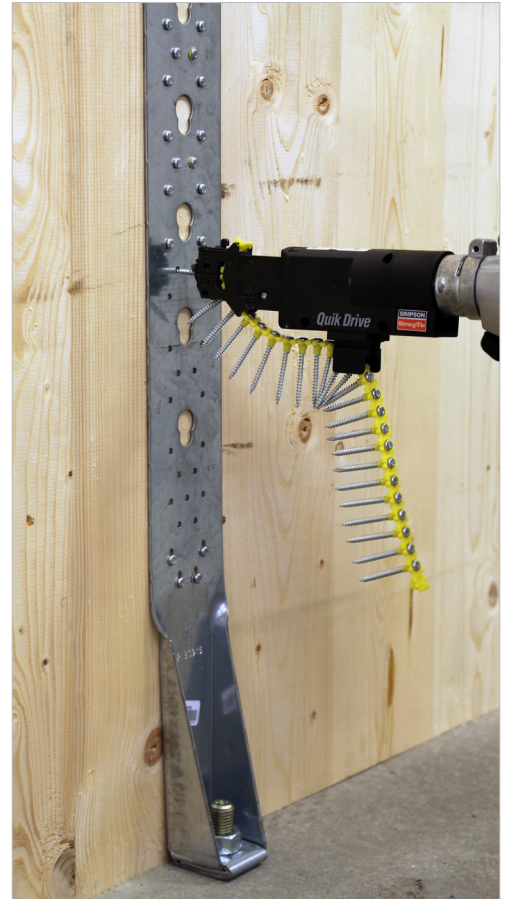

Quik Drive collated CSA screws fastening HTT31 holdown in CLT wall-to-concrete installation.



ETA-04/0013

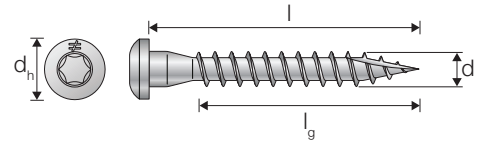

CSA Electro Galvanised

Model No.	Dimensions [mm]				Bit	
	d	l	d _h	l _g		
CSA4.0X30	4.0	30	7.3	24	T-15	250
CSA5.0X25**	5.0	25	8.3	19	T-20	250
CSA5.0X35-R	5.0	35	8.3	29	T-20	25
CSA5.0X35*/**	5.0	35	8.3	29	T-20	250
CSA5.0X35-HV*	5.0	35	8.3	29	T-20	1500
CSA5.0X40-R	5.0	40	8.3	34	T-20	25
CSA5.0X40*/**	5.0	40	8.3	34	T-20	250
CSA5.0X40-HV*	5.0	40	8.3	34	T-20	1500
CSA5.0X50	5.0	50	8.3	34	T-20	250
CSA5.0X80	5.0	80	8.3	44	T-20	200

*) Available with Impreg+ coating.

**) Available in stainless steel A4.



Use Quik Drive collated CSA for efficient installation of large metal plates with multiple fastening repetitions.



© SIMPSON STRONG-TIE® F-EU-SOLIDDRIVE-2022



ETA-04/0013

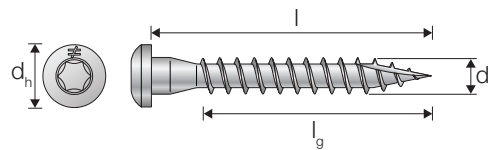

CSA-T Electro Galvanised (Collated for Quik Drive® Systems)

Model No.	Dimensions [mm]				Qty per Strip	Qty per Pack	Recommended RPM	QDBPC50E
	d _h	d	l	l _g				
CSA5.0X35T*	8.3	5.0	35	29	25	1500	2500-4000	✓
CSA5.0X40T*	8.3	5.0	40	34	25	1500	2500-4000	✓
CSA5.0X50T	8.3	5.0	50	34	25	1000	2500-4000	✓

* Also available Quik Drive collated with Impreg+ coating and in stainless steel A4.

Solid-Drive™ WSV Collated Structural WOOD Screw

Simpson Strong-Tie has re-engineered its popular subfloor screws to reduce driving force and increase installation speed. The WSV Subfloor screw has been developed for fastening subfloor sheathing to wood and I-joist framing using the Quik Drive® auto-feed screw driving system.

- Redesigned point and thread pattern provide easy starts and up to 25% less torque¹ — which leads to faster driving²
- Less installation torque also means less wear on tools
- Deep 6-lobe recess and ribbed underhead provide secure bit retention and clean countersinking

Application

- Wood-to-Wood Connections



EN14592



Features

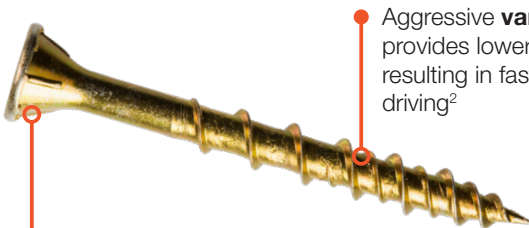

Ribbed head design countersinks easily and provides a clean, finished appearance

Aggressive **variable thread** provides lower driving torque¹, resulting in faster, easier driving²



Deep T-25 **6-Lobe recess** provides improved control and greater bit life



Quik Drive QDPRO76SKE system is designed for efficient installation of timber screws.

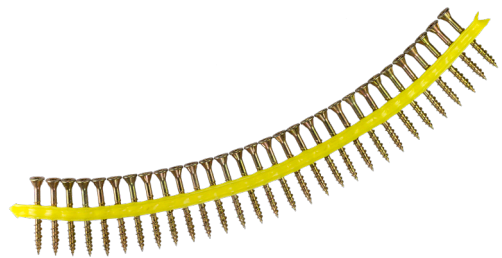

EN14592

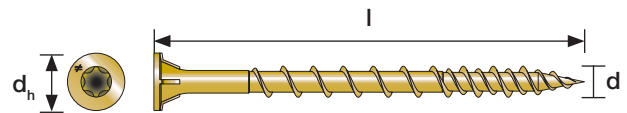

WSV Yellow Zinc Coating (Collated for Quik Drive® Systems)

Model No.	Dimensions [mm]			Qty per Strip	Qty per Pack	Recommended RPM	Bit	Compatible with QDPRO76SKE
	d	l	d _h					
WSV44E	4.6	44	8.5	30	2000	2500-4500	T-25	✓
WSV51E	4.6	51	8.5	30	2000	2500-4500	T-25	✓
WSV64E	4.6	64	8.5	30	1500	2500	T-25	✓
WSV76E	4.6	76	8.5	30	1000	2500	T-25	✓

Each box includes BITTX25 driver bit.

1. Test data shows the WSV Subfloor screw requires up to 25% less driving torque in single-material LVL
2. The redesigned WSV thread pattern will result in 20% faster screw installations

For additional technical data, such as load-bearing capacities, installation data and more, visit our website www.strongtie.eu.

Solid-Drive™ SDW/SDWS Structural WOOD Screws

SDW/SDWS are structural wood screws available in a variety of lengths and are designed for cross-laminated timber assemblies, mass timber construction, log-home construction, ledgers and general interior applications.

These structural fasteners require less torque to install than comparable fasteners, and the large-diameter washer head pulls members down easily, eliminating the need to use extra washers.

Application

- Wood-to-Wood Connections

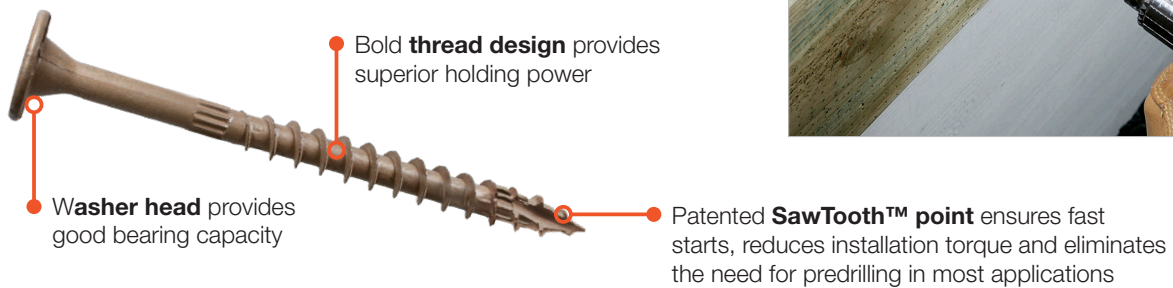

EN14592

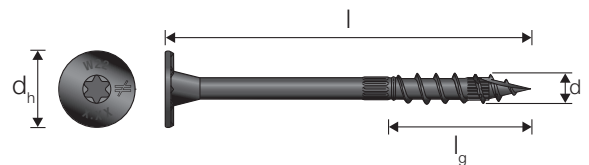

SDW E-Coat

Model No.	Dimensions [mm]				Bit	📦
	d	l	d _h	l _g		
SDW22258-R50	7.9	68	19.4	33	T-40	50
SDW22338-R50	7.9	86	19.4	40	T-40	50
SDW22438-R50	7.9	111	19.4	36	T-40	50
SDW22600-R50	7.9	152	19.4	36	T-40	50



EN14592

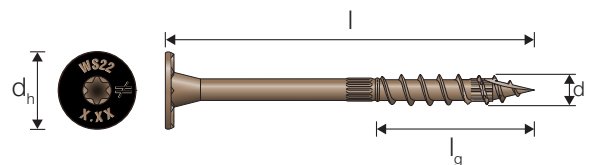

SDWS Double Barrier Coating

Model No.	Dimensions [mm]				Bit	📦
	d	l	d _h	l _g		
SDWS08X75DB	8.0	75	19.2	36	T-40	50
SDWS08X100DB	8.0	100	19.2	58.3	T-40	50
SDWS08X126DB	8.0	126	19.2	66.7	T-40	50
SDWS08X151DB	8.0	151	19.2	67.1	T-40	50
SDWS08X202DB	8.0	202	19.2	67.5	T-40	50
SDWS08X252DB	8.0	252	19.2	67.7	T-40	50

For additional technical data, such as load-bearing capacities, installation data and more, visit our website www.strongtie.eu.

GSCREW SCREW GUIDE for 45° and 60° inclined installations

The GSCREW4560 screw guide assists with the installation of any structural screws with a diameter between 8,0 and 12,0 mm with an inclined angle of 45° to 60°.

The screw guide is suitable for the installation of full threaded screws or double threaded screws in structural timber, LVL, glulam or CLT applications or for fastening roof insulation, where 45° or 60° inclined installations are common. However, it can also be used for any type of application as long as the screw is longer than 100 mm for a 45° configuration and longer than 140 mm for a 60° configuration.

This screw guide allows for easy installation of the screws at the required angle.

GSCREW guide

Item code	Description
GSCREW4560-R	GSCREW4560-R for right handed installer (right hand on screwdriver and left hand on screw guide)
GSCREW4560-L	GSCREW4560-L for left handed installer (left hand on screwdriver and right hand on screw guide)

Compatible screws:

Installation angle	Minimum screw length	
	Ø8, Ø10 and Ø12	SSH Ø12
45°	100 mm	120 mm
60°	140 mm	160 mm



Example of inclined installation - GSCREW4560-R

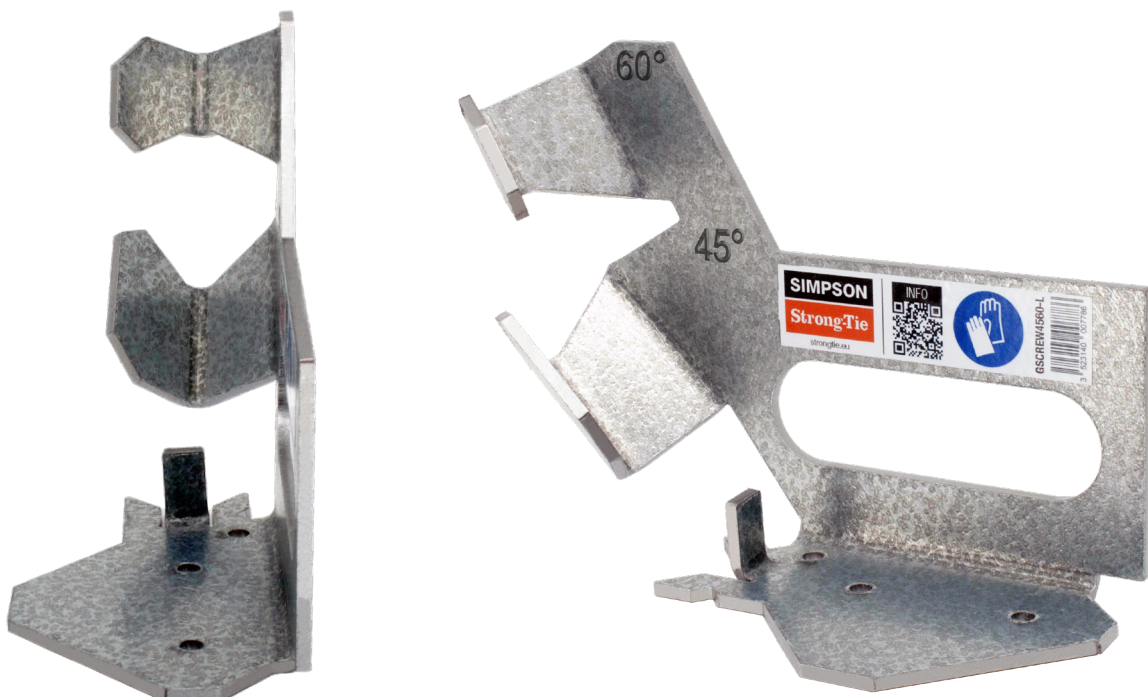

Installation examples:

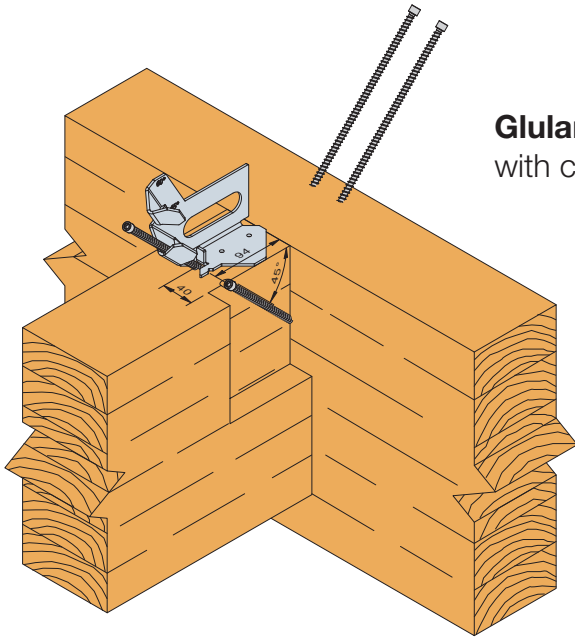

Glulam joist on beam connection with crossed screws (45°)

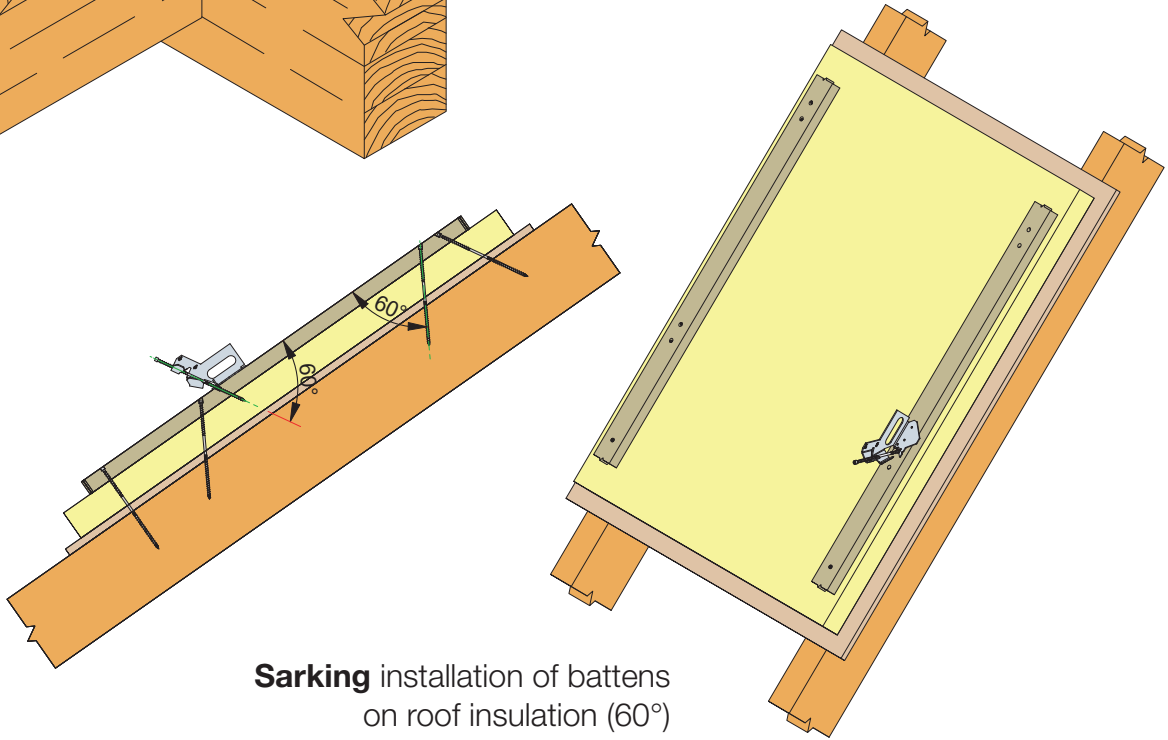

Sarking installation of battens on roof insulation (60°)

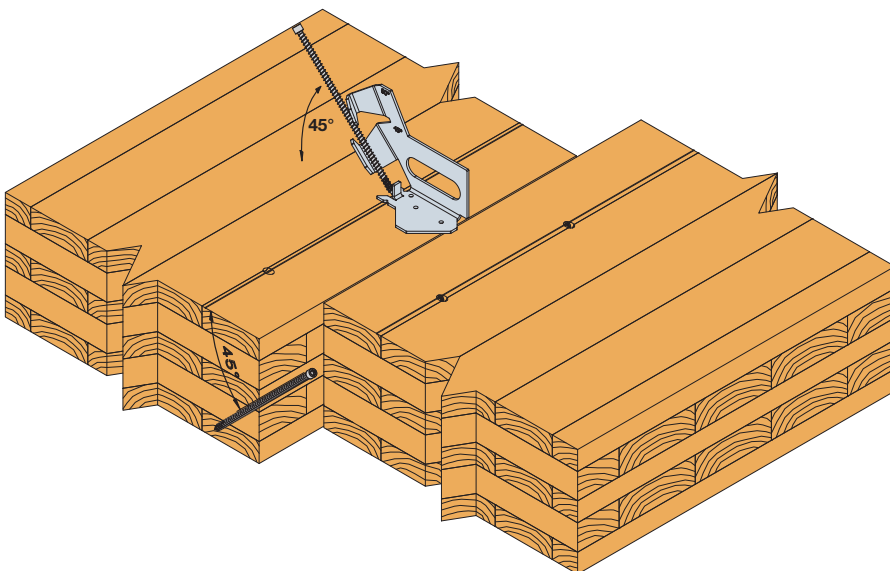

CLT assembly of two floor panels (45°)



Calculating wood fastening connections has never been easier

In just four simple steps, Solid Wood helps you calculate and select fastening solutions suitable for the specific wood structure at hand, according to Eurocode 5 and our ETA.

- **Time saving** - Quicker and easier than doing manual calculations
- **Safety** - Removes any doubt in the precision of your manual calculations
- **Product guide** - Helps you find the correct product for your application

The software generates a PDF-report that can be used as documentation for the project.

solidwood.strongtie.eu



Calculation in four simple steps.

